

# Introducción a los Compuestos con Enlace Metal-Metal: Cluster Metálicos

## 1. Introducción

Un grupo de dos o más átomos metálicos entre los cuales hay una densidad electrónica de enlace.

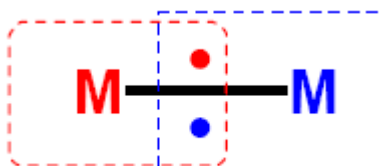

Sin embargo, muchas veces también se utiliza el término cluster para señalar complejos polinucleares (*agregados*) del tipo clásico.

Se pueden clasificar en dos grupos

### Cluster Carbonilo (CO)

E.O. +1, 0, -1

M-M largos  $< 2.80 \text{ \AA}$

Metales de los últimos grupos. (1<sup>a</sup>, 2<sup>a</sup> y 3<sup>a</sup>)

### Cluster Haluro

E.O. mas altos

Metales de los primeros grupos (2<sup>a</sup> y 3<sup>a</sup>)

## 2. Cluster Metal Carbonilo

- ❖ Son frecuentes los cluster aniónicos o con hidruros
- ❖ Los compuestos catiónicos son virtualmente desconocidos

## Se pueden clasificar como:

**Cluster carbonilo de baja nuclearidad (LNCC):** cuando el número de metales del cluster es:  $n = 3,4$

**Cluster carbonilo de alta nuclearidad (HNCC):** cuando el número de metales del cluster es:  $n \geq 5$

### a. Cluster de Baja Nuclearidad ( $M_2$ , $M_3$ y $M_4$ )

#### Compuestos dinucleares

❖ Con enlace simple M-M

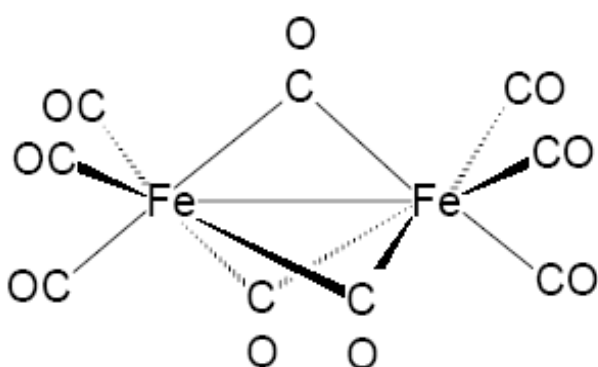

$Fe_2(CO)_9$   $D(Fe-Fe) = 246$  pm,  $Fe^0$ ,  $d^8$

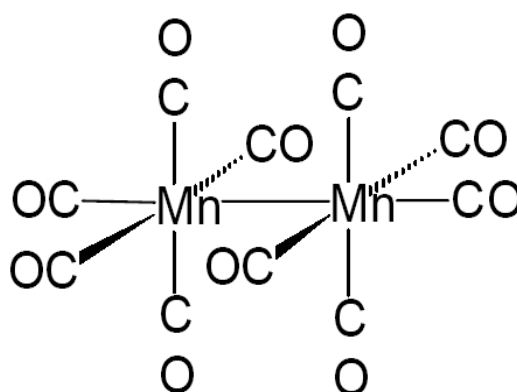

$[Mn_2(CO)_{10}]$   $D(Mn-Mn) = 293$  pm  
 $Mn^0$ ,  $d^7$

❖ Con enlace múltiple M-M

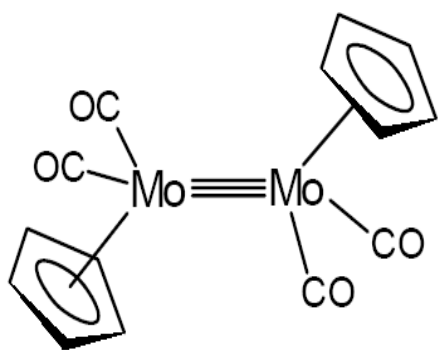

$[Cp_2Mo_2(CO)_4]$   $D(Mo-Mo) = 245$  pm  
 $Mo^{1+}$ ,  $d^5$

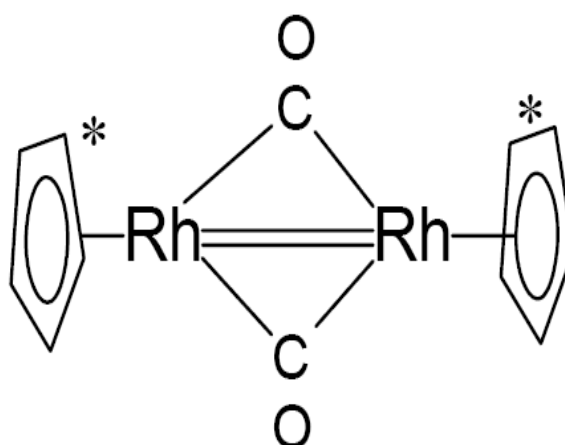

## Compuestos trinucleares

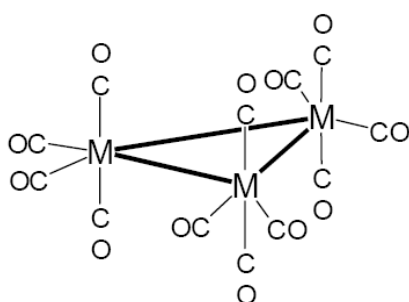
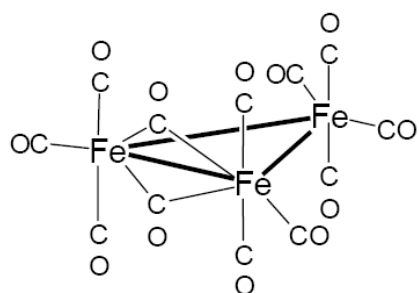

M = Ru, Os

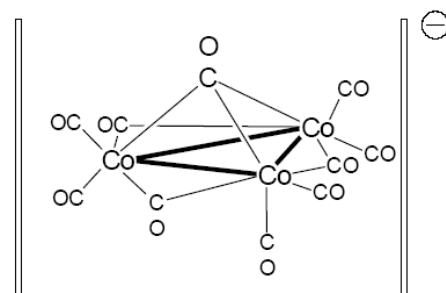

También hay cluster con ligandos adicionales al CO

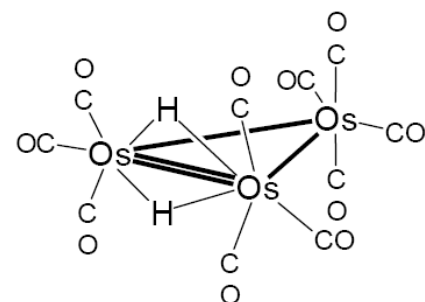
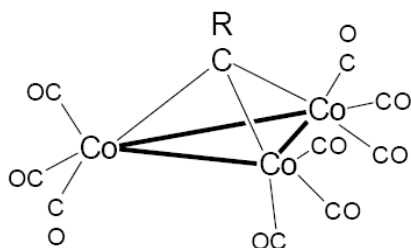
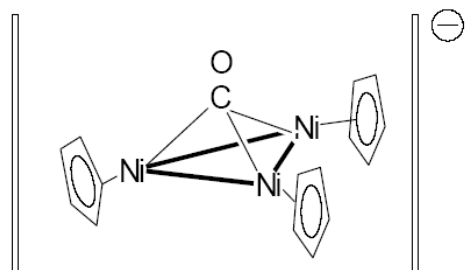

Os=Os = 268 pm, Os-Os = 282 pm

## Compuestos tetranucleares

Pueden tener tres estructuras distintas

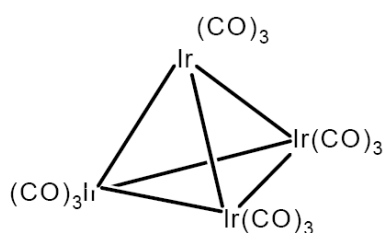

Tetraédrica

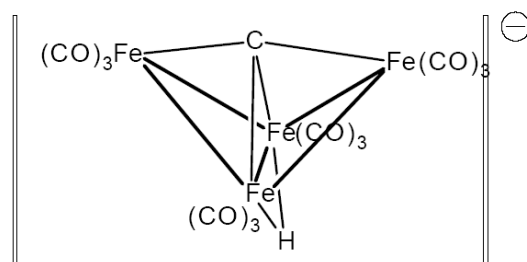

Mariposa

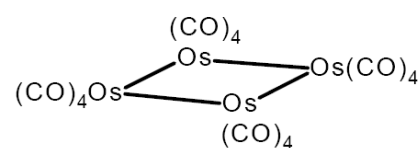

Plano cuadrado

## ¿Cómo determinar el número de enlaces M-M?

- ❖ N° Total de electrones en el cluster (asumiendo que todos los metales obedecen la regla de los 18 e-)
- ❖ N° mágico =  $18N - 2M$ 
  - N es el número de átomos metálicos
  - M es el número de enlace metal-metal

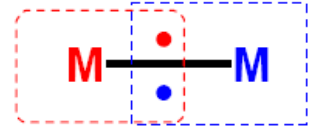

Ejemplo:  $\text{Os}_3(\text{CO})_{12}$

Geometría triangular  $n=3$ ;

N° Mágico =  $3 \times 18 - 3 \times 2 = 48 e^-$

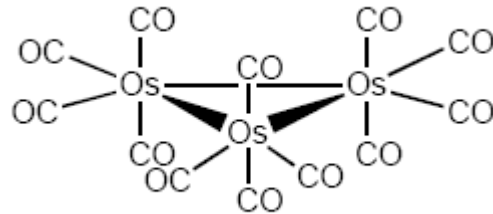

Os: grupo 8,  $d^8$ ;

CO: 2e dador

N° Total de electrones en el cluster  $3 \times 8 + 12 \times 2 = 48$

$\text{Os}_3(\text{CO})_{10}\text{H}_2$

Geometría triangular  $n=3$ ;

N° Mágico =  $3 \times 18 - 3 \times 2 = 48 e^-$

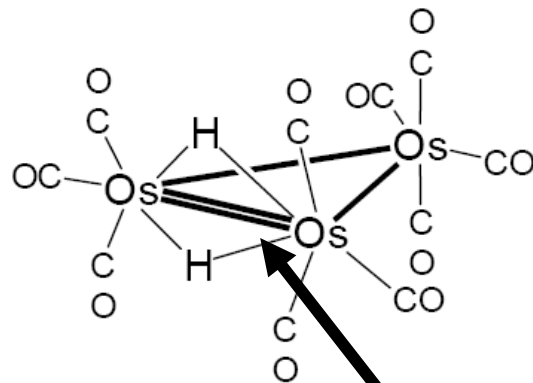

$\text{Os}=\text{Os} = 268 \text{ pm}$ ,  $\text{Os}-\text{Os} = 282 \text{ pm}$

Os: grupo 8,  $d^8$ ;

CO: 2e dador

H: 1e dador

N° Total de electrones en el cluster  $3 \times 8 + 10 \times 2 + 1 \times 2 = 46 e^-$

Faltan dos electrones luego hay que añadir un enlace doble adicional

### b. Cluster de Alta Nuclearidad (HNCC)

Son los que tienen cinco o más átomos metálicos

# Estructuras de los Cluster de alta nuclearidad(I)

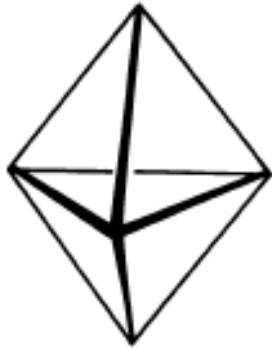

trigonal bipyramid  
N = 5

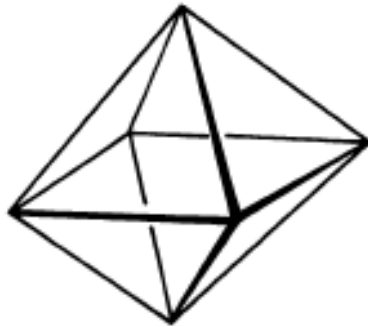

octahedron  
N = 6

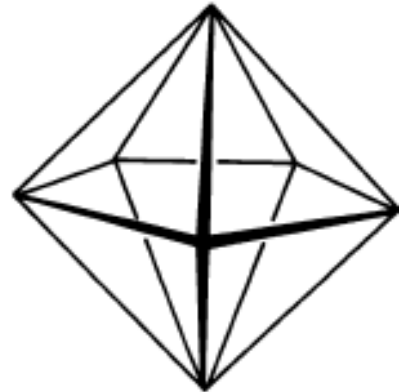

pentagonal bipyramid  
N = 7



dodecahedron  
N = 8



tricapped trigonal prism  
N = 9



bicapped square  
antiprism  
N = 10

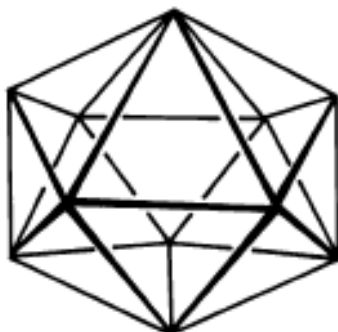

octadecahedron  
N = 11



icosahedron  
N = 12

16.8

i. Estructuras: Poliedros con caras triangulares "deltaedros"

**Estructuras closo:**  
 $S = n + 1$

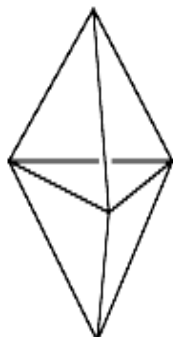

Trigonal bipyramid  
 $n = 5, S = 6, k = 72$



Octahedron  
 $n = 6, S = 7, k = 86$

**Estructuras nido:**  
 $S = n + 2$

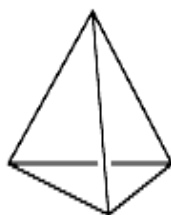

*nido*-Trigonal bipyramid  
 (Tetrahedron)  
 $n = 4, S = 6, k = 60$

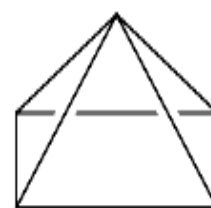

*nido*-Octahedron  
 (square based pyramid)  
 $n = 5, S = 7, k = 74$

**Estructuras arachno:**  
 $S = n + 3$

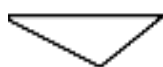

















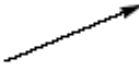

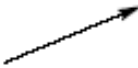





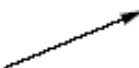

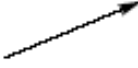



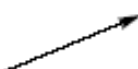

*arachno*-Trigonal bipyramid  
 (Triangle)  $n = 3, S = 6, k = 48$

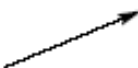

*arachno*-Octahedron  
 ("Butterfly")  
 $n = 4, S = 7, k = 62$

$n = n^\circ$  de átomos metálicos ( $n^\circ$  vértices);  $S = n^\circ$  de pares de  $e^-$  esquelatales;  
 $k = n^\circ$  total de electrones de valencia

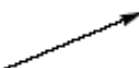
# Estructuras de los Cluster de alta nuclearidad(II)

No. of Vertices	Closo		Nido		Arachno
4 (5 PSEP) tetrahedron					
5 (6 PSEP) trigonal bipyramid					
6 (7 PSEP) octahedron					
7 (8 PSEP) pentagonal bipyramid					
8 (9 PSEP) triangular dodecahedron					
9 (10 PSEP) tricapped trigonal prism					
10 (11 PSEP) bicapped square antiprism				 ≡	
11 (12 PSEP) octadecahedron					
12 (13 PSEP) icosahedron					

nido 11 = arachno 12

## Reglas de Wade o PSEPT

❖  $N = n^\circ$  de átomos metálicos ( $n^\circ$  vértices);

❖  $S = n^\circ$  de pares de  $e^-$  esqueléticos;

- Ccloso  $S = n + 1$
- nido  $S = n + 2$
- arachno  $S = n + 3$
- hypho  $S = n + 4$

### b. Heteroátomos en los Cluster Metálicos

Los heteroátomos **no constituyen vértices** del cluster **pero contribuyen** con sus electrones de valencia a los electrones esqueléticos

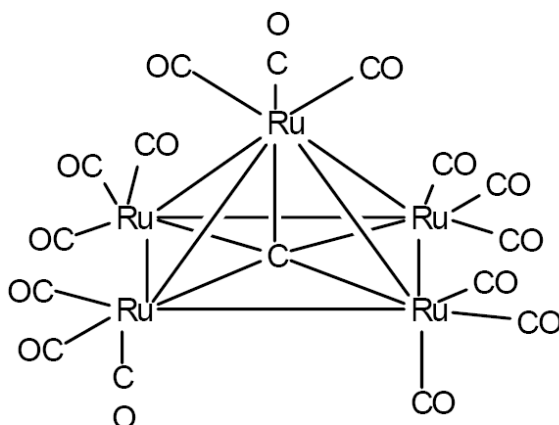

### c. Recuento de electrones en Cluster de Alta Nuclearidad

#### Total electron count (TEC)

❖ No. de electrones de valencia de los metal **(a)** (e.g. 8 por Ru)

**2e** por CO (sin importar de que tipo sea) **(b)**

**1e** por cada carga negativa **(c)**

❖ No. de electrones de valencia los átomos hetero y/o **intersticiales** (1 por H, 4 por C, 5 por P etc.) **(d)**

**TEC = (a) + (b) + (c) + (d)**

Asumiendo que **12e por metal** están relacionados en enlaces **M-CO**.

❖  $S = (TEC - 12xn)/2$ , donde n = no. de Metales

Para los cluster *cloro*, como  $S = n + 1$

$$n + 1 = (TEC - 12n)/2$$

$$TEC = 2n + 2 + 12n = 14n + 2$$

Análogamente,

$$TEC = 14n + 4(nido)$$

$$TEC = 14n + 6(arachno)$$

Ejemplos:



$$TEC = 6 \times 8 + 18 \times 2 + 2 = 86$$

$$S = (86 - 12 \times 6) / 2 = 7 \quad (n + 1)$$

6-vértices.

Polihedro **cloro**

Octaedro

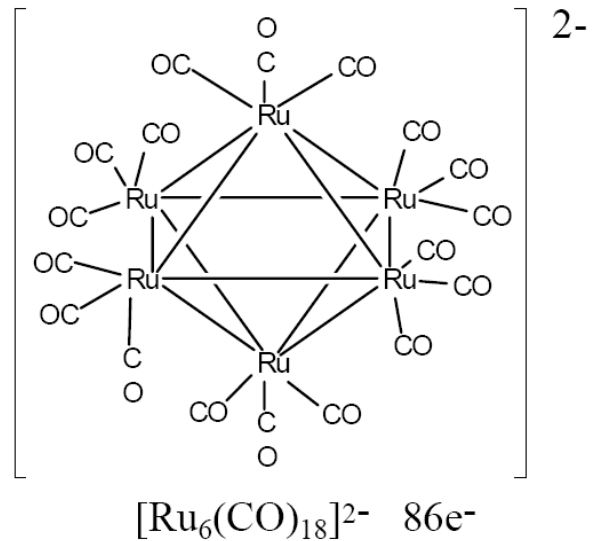

(carburo intersticial)

$$TEC = 6 \times 8 + 4 + 17 \times 2 = 86$$

$$S = (86 - 6 \times 12) = 7(n + 1)$$

6-vértices.

Polihedro **cloro**

Octaedro

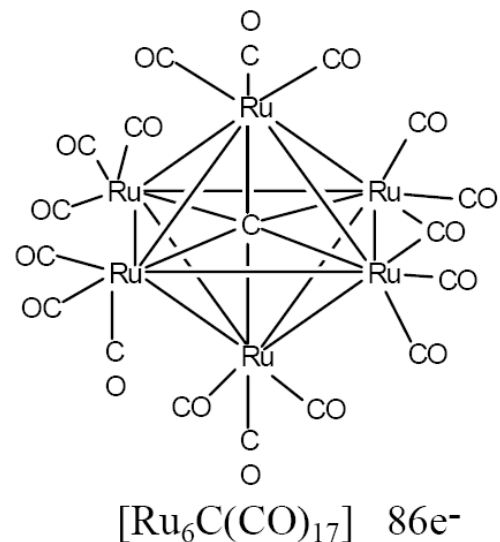

$\text{Ru}_5\text{C}(\text{CO})_{15}$ (cluster carburo)

$\text{TEC} = 5 \times 8 + 4 + 15 \times 2 = 74$

$\text{S} = (74 - 12 \times 5) / 2 = 7 (n + 2)$

5-vertices

Poliedro **nido**

Octaedro-1 4-vértices (pirámide cuadrada)

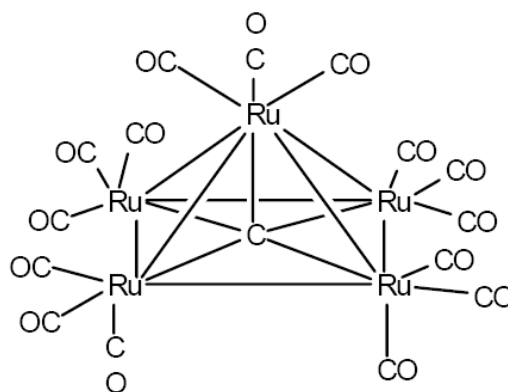

$\text{Ru}_5\text{C}(\text{CO})_{15} 74e^-$

## Estructuras de los Cluster de alta nuclearidad **apicados**

- Muchos cluster carbonilos consisten en un poliedro central donde alguna o algunas de las caras tienen otro “vértice”.
- Los grupos en estos nuevos “vértices” se les denomina **apicales**.
- Las unidades **apicales** no modifican el número de electrones **esqueletales, S**
- Por lo tanto solo incrementan el número de electrones totales en 12 por cada átomo **apical**

# Estructuras de los Cluster de alta nuclearidad apicados

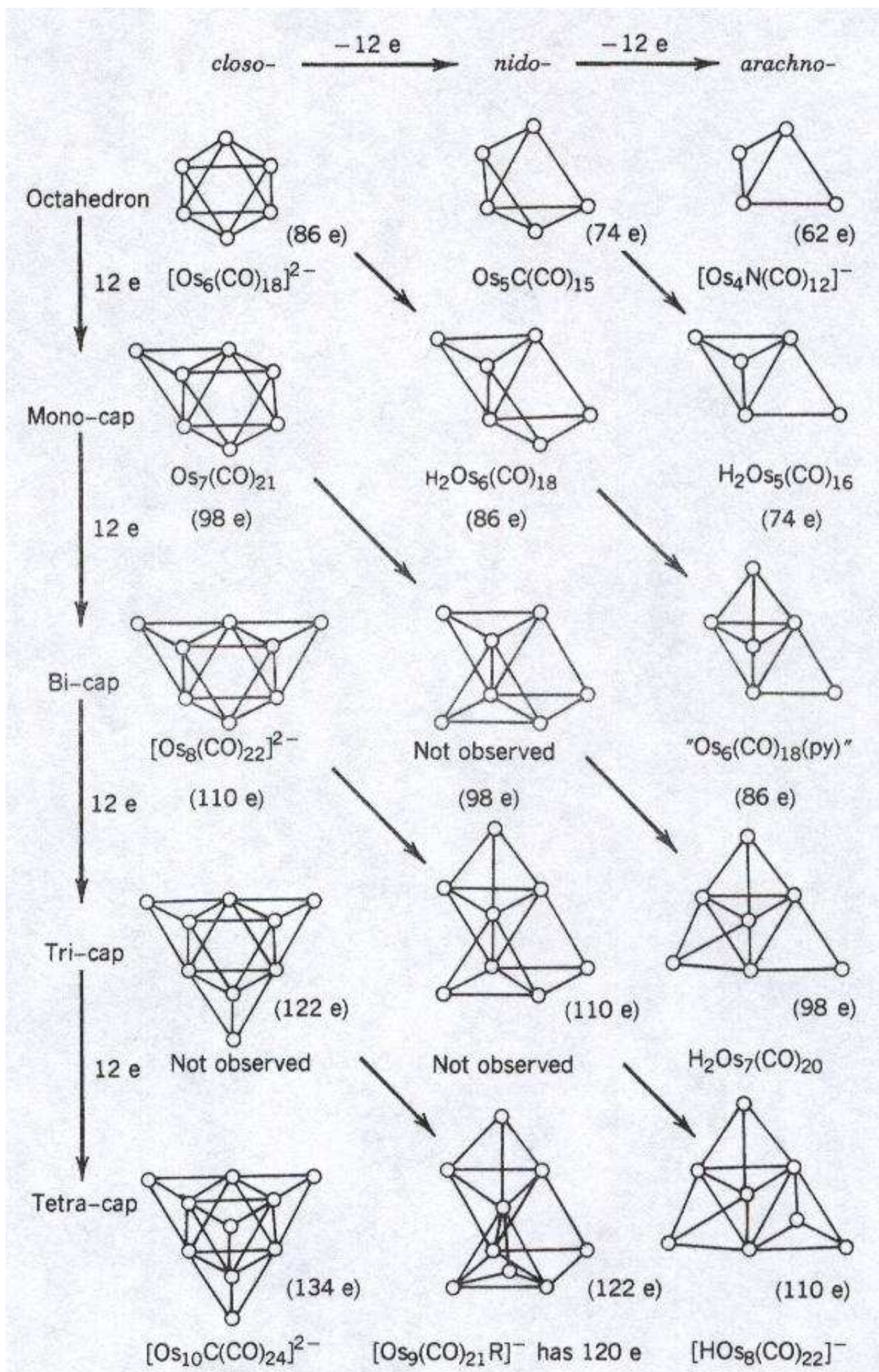

#### d. Métodos de Síntesis

El método de síntesis más habitual es la Pirolisis y produce bajos rendimientos y selectividades muy escasas.

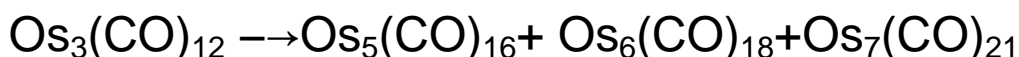

Otro método es la reducción

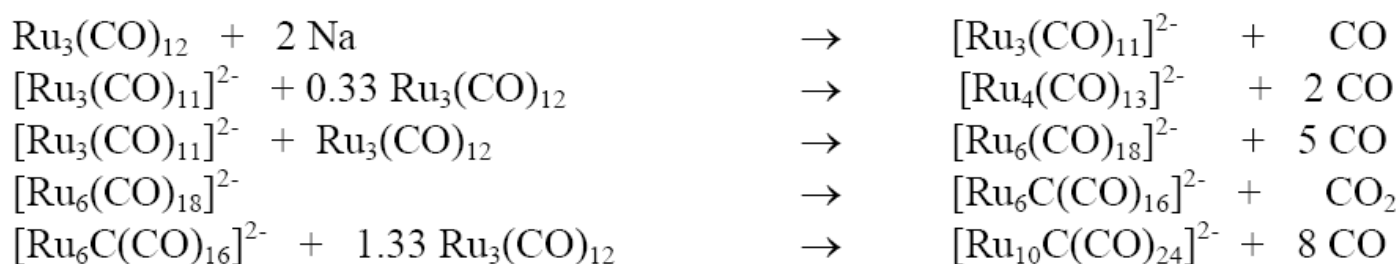

### 3. Cluster Haluro y Calcogenuro

#### a. Cluster Octaédricos

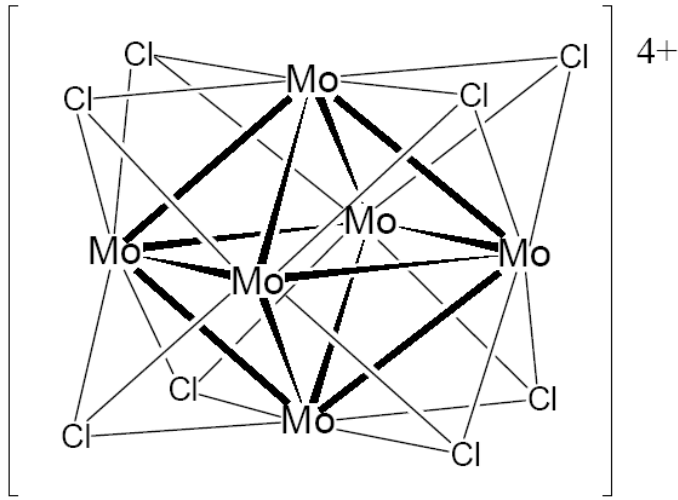

$[\text{Mo}_6\text{Cl}_8]^{4+}$   $D(\text{Mo-Mo}) = 260 \text{ pm}$

electrones  $d$  /Mo = 6  
 Total  $d$  electrons =  $36 - 8 - 4 = 24$   
 No. contactos Mo-Mo = 12  
 Mo-Mo orden de enlace = 1

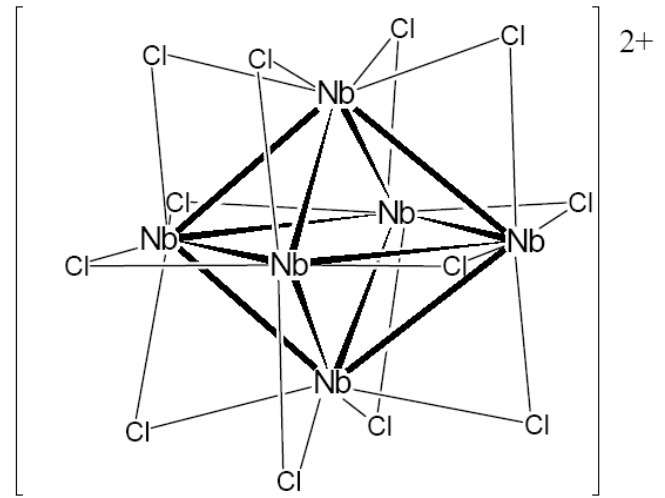

$[\text{Nb}_6\text{Cl}_{12}]^{2+}$   $D(\text{Nb-Nb}) = 290 \text{ pm}$

electrones  $d$  /Nb = 5  
 Total  $d$  electrons =  $30 - 12 - 2 = 16$   
 No. contactos Nb-Nb = 12  
 Nb-Nb orden de enlace =  $2/3$

#### b. Cluster Triangulares

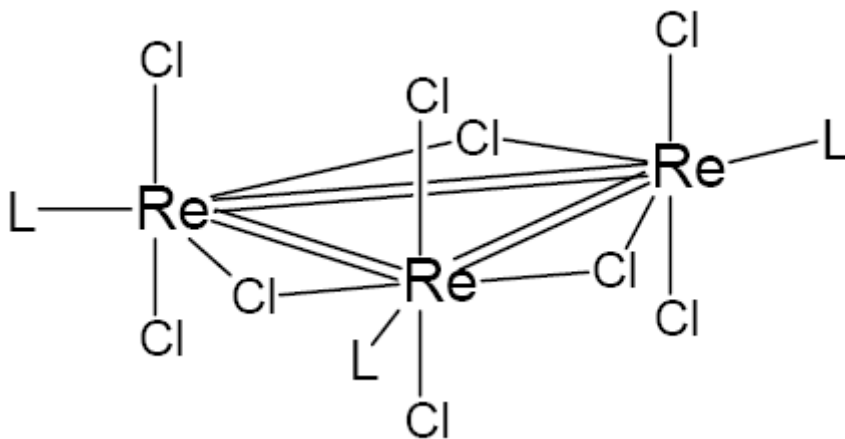

Electrones  $d$  /Re = 7  
 Total  $d$  electrons =  $21 - 9 = 12$   
 No. contactos Mo-Mo = 3  
 Re-Re orden de enlace = 2

#### 4. Compuestos con enlace Múltiple M-M

##### a. Principales tipos

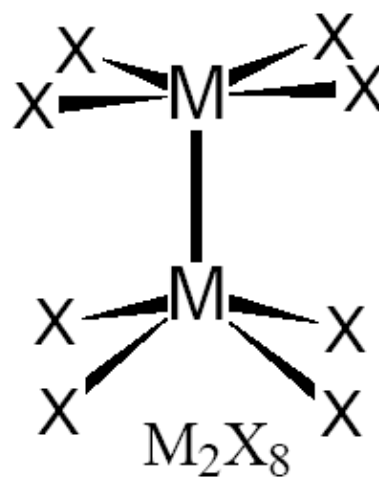
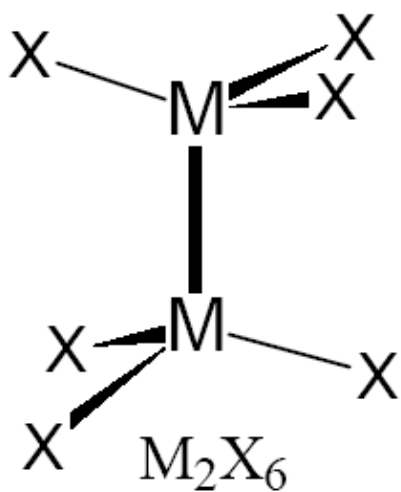

##### b. Enlace cuádruples

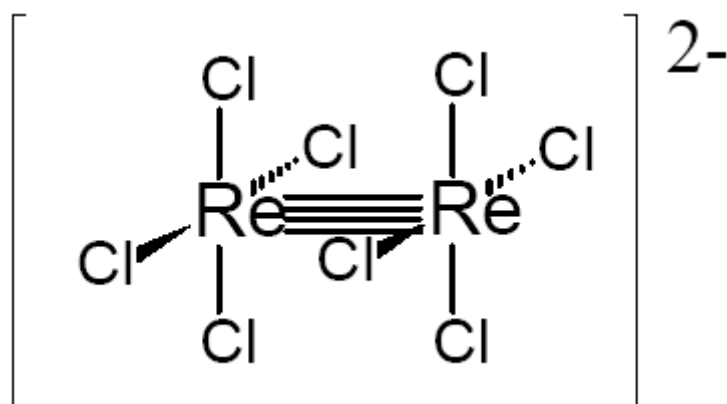

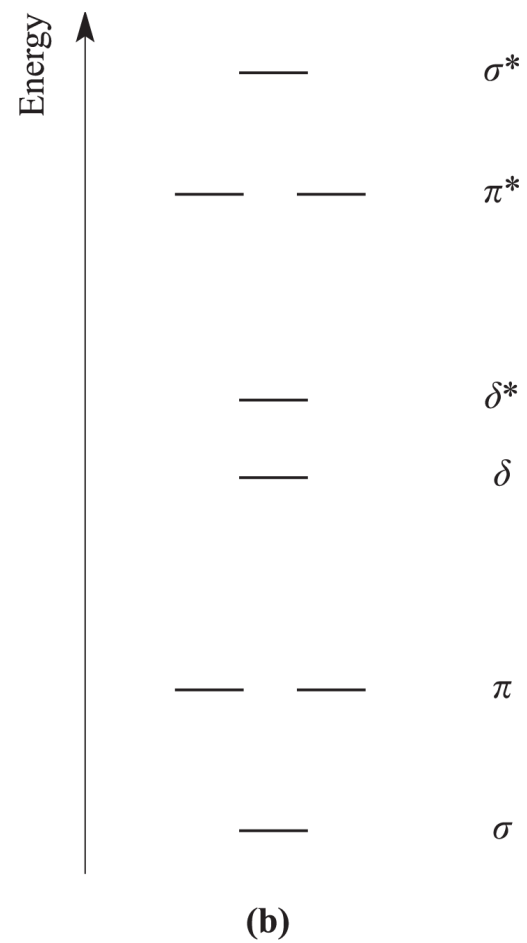
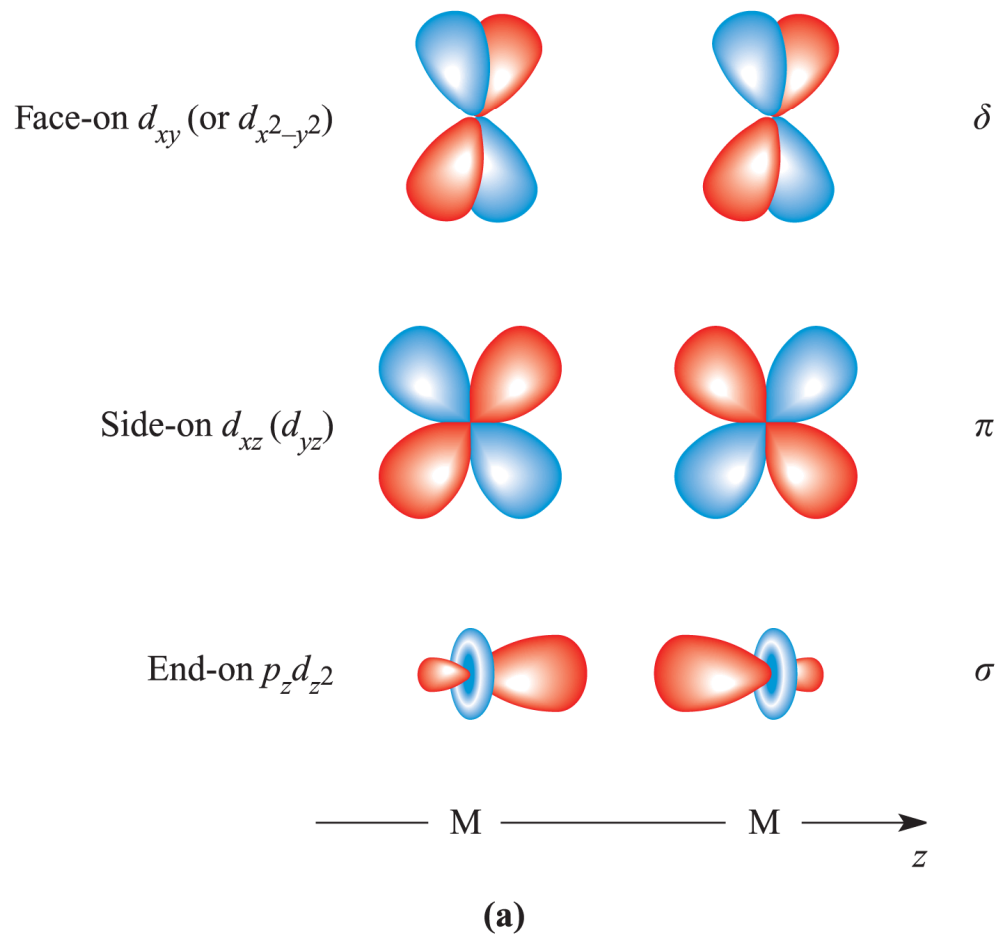

## Otros Órdenes de Enlace

No. <i>d</i> Electrons	2	3	4	5	6	7	8	9	10	11	12	13	14
$\sigma^*$	—	—	—	—	—	—	—	—	—	—	—	—	—
$\pi^*$	==	==	==	==	==	==	==	==	==	≠	≠	≠	≠
$\delta^*$	—	—	—	—	—	—	+						
$\delta$	—	—	—	—	—	+							
$\pi$	==	≠	≠	≠	≠	≠	≠	≠	≠	≠	≠	≠	≠
$\sigma$													
Bond Order	1	1.5	2	2.5	3	3.5	4	3.5	3	2.5	2	1.5	1

Correlation of bond order with number of *d* electrons

Relación del Orden de Enlace en los Cluster dinucleares con los electrones de Valencia

# Enlace quíntuple 2005

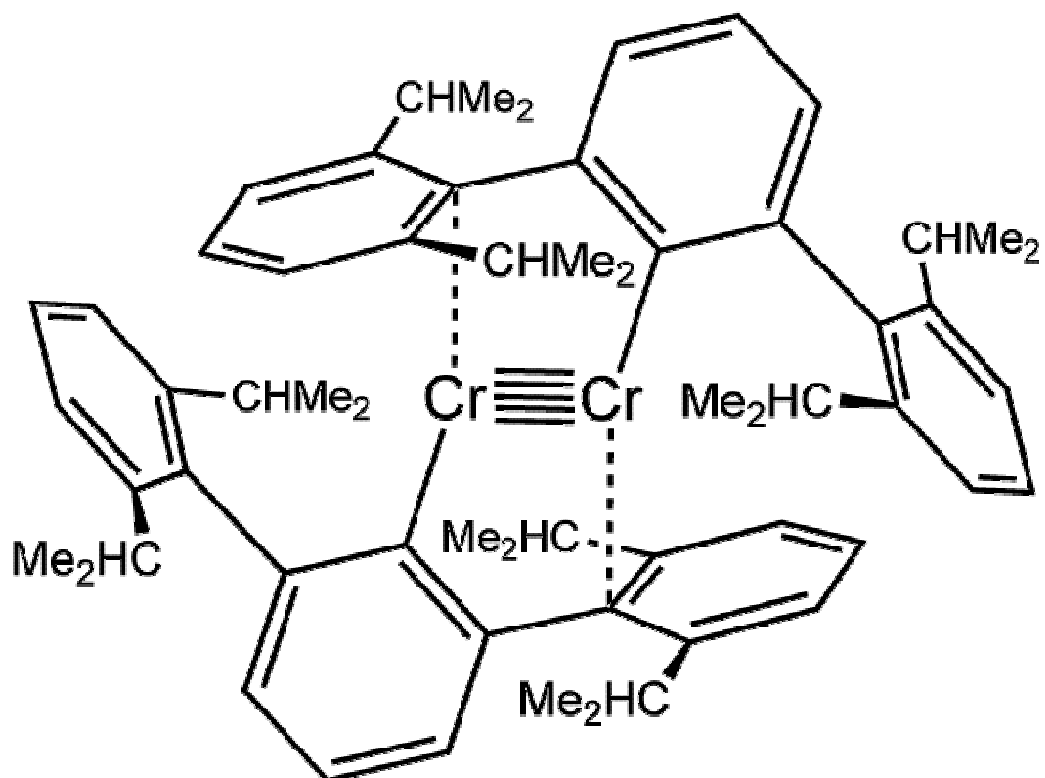

Descrito como:  $\sigma^2\pi^4\delta^4$

$D_{\text{Cr-Cr}}$  1.808Å

$r_{\text{Cr}}$  1.27