

Voltage stability constrained OPF market models considering $N - 1$ contingency criteria

Federico Milano^a, Claudio A. Cañizares^{b,*}, Marco Invernizzi^c

^a Department of Electrical Engineering, University of Castilla-La Mancha, Ciudad Real 13071, Spain

^b Department of Electrical and Computer Engineering, University of Waterloo, Waterloo, Ont., Canada N2L 3G7

^c Department of Electrical Engineering, University of Genoa, Genoa 16145, Italy

Received 29 March 2004; accepted 1 July 2004

Available online 22 December 2004

Abstract

This paper proposes two novel techniques for including contingencies in OPF-based electricity market computations and for the estimation of a “system-wide” available transfer capability (SATC). The OPF problem formulation includes voltage stability constraints and a loading parameter in order to ensure a proper stability margin for the market solution. Two methods are proposed. The first technique is an iterative approach and computes an SATC value based on an $N - 1$ contingency criterion for an initial optimal operating condition, to then solve an OPF problem for the worst contingency case; this process is repeated until the changes in the SATC values are below a minimum threshold. The second approach solves a reduced number of OPF problems associated with contingency cases according to a ranking based on a power transfer sensitivity analysis of the transmission lines. Both methods are tested on a 6-bus system and on a realistic 129-bus Italian network model considering supply and demand side bidding. Local marginal prices and nodal congestion prices resulting from the proposed solutions as well as comparisons with results obtained by means of a standard OPF technique are also presented and discussed.

© 2004 Elsevier B.V. All rights reserved.

Keywords: Electricity markets; Optimal power flow; $N - 1$ contingency criterion; Transmission congestion; Available transfer capability

1. Introduction

The worldwide deregulation and/or privatization of electricity markets has led in recent years to different competitive market structures, which can be grouped in three main categories. These are centralized markets, standard auction markets, and spot-pricing or hybrid markets. Although several studies have been published regarding the definition of a complete market model able to account for both economic and security aspects, the inclusion of the “correct” stability constraints and the determination of fair security prices has not been properly addressed.

This paper focuses on hybrid markets and proposes two methods for the proper inclusion of contingencies and sta-

bility constraints through the use of a voltage stability constrained optimal power flow (VSC-OPF) [1,2]. The OPF problem is solved using an interior point method (IPM) that has proven to be robust and reliable for realistic size networks [3]. A proper representation of voltage stability constraints and maximum loading conditions, which may be associated with limit-induced bifurcations or saddle-node bifurcations, is used to represent the stability constraints in the OPF problem [1,2,4–6]. This technique has been applied to solve diverse OPF market problems as demonstrated in [7,8].

Contingency constrained OPFs have been previously proposed based on linear programming techniques [9–11]. Some studies for contingency planning and voltage security preventive control have also been presented in [12–14], and the issue of OPF computations with inclusion of voltage stability constraints and contingencies is discussed in [15], based on a heuristic methodology. However, the proper accounting of system contingencies in the VSC-OPF market problem is yet

* Corresponding author. Tel.: +1 519 888 4567x5355; fax: +1 519 746 3077.

E-mail address: fmilano@ind-cr.uclm.es (F. Milano), c.canizares@ece.uwaterloo.ca (C.A. Cañizares), minverni@epsr.die.unige.it (M. Invernizzi).

to be addressed in the technical literature, and is the main thrust of this paper.

This paper uses an approach similar to [16], where the authors proposed a technique to account for system security through the use of voltage-stability-based constraints, and to provide an estimation of the system congestion, through the value of a “system-wide” available transfer capability (SATC) as proposed in [17]. With this aim, voltage and power transfer limits are not computed off-line, which is the current common strategy, but are properly represented in on-line market computations by means of the inclusion of a loading parameter in the system stability constraints. In this paper, the basic technique initially proposed in [16] and expanded in [2] is further developed to include contingencies, such that an accurate evaluation of the SATC can be obtained.

The paper is organized as follows. Section 2 presents the basic concepts on which the proposed methodologies are based; the definitions of SATC and of local marginal prices and nodal congestion prices are also discussed in this section. Section 3 discusses two novel techniques to account for contingencies in the OPF problem, with particular emphasis on their application to OPF-based electricity market models. The applications of the proposed techniques are illustrated in Section 4 for a 6-bus test system and a realistic 129-bus test system based on a model of the Italian HV transmission network assuming elastic demand bidding; for both test systems, results are compared with respect to solutions obtained with a standard OPF-based market technique. Finally, Section 5 discusses the main contributions of this paper as well as possible future research directions.

2. Voltage stability constrained OPF

The OPF-based approach is typically formulated as a nonlinear constrained optimization problem, consisting of a scalar objective function and a set of equality and inequality constraints. A “standard” OPF-based market model can be represented using the following security constrained optimization problem (e.g. [18]):

$$\begin{aligned}
 \text{Min.} \quad & -(C_D^T P_D - C_S^T P_S) && \rightarrow \text{Social benefit} \\
 \text{s.t.} \quad & f(\delta, V, Q_G, P_S, P_D) = 0 && \rightarrow \text{PF equations} \\
 & 0 \leq P_S \leq P_{S_{\max}} && \rightarrow \text{Sup. bid blocks} \\
 & 0 \leq P_D \leq P_{D_{\max}} && \rightarrow \text{Dem. bid blocks} \\
 & |P_{ij}(\delta, V)| \leq P_{ij_{\max}}, |P_{ji}(\delta, V)| \leq P_{ji_{\max}} && \rightarrow \text{Power transfer lim.} \\
 & I_{ij}(\delta, V) \leq I_{ij_{\max}}, I_{ji}(\delta, V) \leq I_{ji_{\max}} && \rightarrow \text{Thermal limits} \\
 & Q_{G_{\min}} \leq Q_G \leq Q_{G_{\max}} && \rightarrow \text{Gen. } Q \text{ lim.} \\
 & V_{\min} \leq V \leq V_{\max} && \rightarrow V \text{ “security” lim.}
 \end{aligned} \tag{1}$$

where C_S and C_D are vectors of supply and demand bids in \$/MWh, respectively, Q_G stands for the generator reactive powers, V and δ represent the bus phasor voltages, P_{ij} and P_{ji} represent the power flowing through the lines in both directions, and are used to model system security by limiting the

transmission line power flows, together with line current I_{ij} and I_{ji} thermal limits and bus voltage limits, and P_S and P_D represent bounded supply and demand power bids in MW. In this model, which is typically referred to as a security constrained OPF market model, P_{ij} and P_{ji} limits are obtained by means of off-line stability studies, based on an $N - 1$ contingency criterion. Thus, taking out one line that realistically creates stability problems at a time, the maximum power transfer limits on the remaining lines are determined through angle and/or voltage stability analyses; the minimum of these various maximum limits for each line is then used as the limit for the corresponding OPF constraint. In practice, however, these limits are typically determined based mostly on power-flow-based voltage stability studies [19].

2.1. Voltage stability constrained OPF (VSC-OPF) market model

In this paper, the security constrained OPF is modified as proposed in [1,2,6,16], so that system security is better modeled through the use of voltage stability conditions. Thus, the VSC-OPF market problem can be stated as follows:

$$\begin{aligned}
 \text{Min.} \quad & G = -(C_D^T P_D - C_S^T P_S) - k\lambda_c && \rightarrow \text{Social benefit} \\
 \text{s.t.} \quad & f(\delta, V, Q_G, P_S, P_D) = 0 && \rightarrow \text{PF equations} \\
 & f_c(\delta_c, V_c, Q_{G_c}, \lambda_c, P_S, P_D) = 0 && \rightarrow \text{“Critical” PF eqs.} \\
 & \lambda_{c_{\min}} \leq \lambda_c \leq \lambda_{c_{\max}} && \rightarrow \text{Loading margin} \\
 & 0 \leq P_S \leq P_{S_{\max}} && \rightarrow \text{Sup. bid blocks} \\
 & 0 \leq P_D \leq P_{D_{\max}} && \rightarrow \text{Dem. bid blocks} \\
 & I_{ij}(\delta, V) \leq I_{ij_{\max}}, I_{ji}(\delta, V) && \\
 & \leq I_{ji_{\max}}, I_{ij}(\delta_c, V_c) && \\
 & \leq I_{ji_{\max}}, I_{ji}(\delta_c, V_c) \leq I_{ji_{\max}} && \rightarrow \text{Thermal limits} \\
 & Q_{G_{\min}} \leq Q_G \leq Q_{G_{\max}}, && \\
 & Q_{G_{\min}} \leq Q_{G_c} \leq Q_{G_{\max}} && \rightarrow \text{Gen. } Q \text{ limits} \\
 & V_{\min} \leq V \leq V_{\max}, && \\
 & V_{\min} \leq V_c \leq V_{\max} && \rightarrow V \text{ “security” lim.}
 \end{aligned} \tag{2}$$

In this case, along with the current system equations f that provide the operating point, a second set of power flow equations f_c and constraints with a subscript c are introduced to represent the system at a maximum loading condition, which can be associated with any given system limit or a voltage stability condition. Equations f_c are associated with a loading parameter λ_c (expressed in p.u.), which ensures that the system has the required margin of security. The loading margin λ_c is also included in the objective function through a properly scaled weighting factor k to guarantee the required maximum loading conditions ($k > 0$ and $k \ll 1$ to avoid affecting market solutions [2]). This parameter is bounded within minimum and maximum limits, respectively, to ensure a minimum security margin in all operating conditions and to avoid “excessive” levels of security. Observe that the higher the value of $\lambda_{c_{\min}}$, the more “congested” the solution for the system would be. An improper choice of $\lambda_{c_{\min}}$ may result in an unfeasible OPF problem if a voltage stability limit (collapse point) corresponding to a system singularity (saddle-node bifurcation) or

a given system controller limit like generator reactive power limits (limit-induced bifurcation) is encountered [20,21].

For the current system equations f and the “critical” system equations f_c , the generator and load powers are defined as follows:

$$\begin{aligned} P_G &= P_{G_0} + P_S \\ P_L &= P_{L_0} + P_D \\ P_{G_c} &= (1 + \lambda_c + k_{G_c})P_G \\ P_{L_c} &= (1 + \lambda_c)P_L \end{aligned} \quad (3)$$

where P_{G_0} and P_{L_0} stand for generator and load powers which are not part of the market bidding (e.g. must-run generators, inelastic loads), and k_{G_c} represents a scalar variable used to distribute the system losses associated *only* with the solution of the power flow equations f_c proportional to the power injections obtained in the solution process, i.e. a standard distributed slack bus model is used. It is assumed that the losses associated with the loading level defined by λ_c in (2) are distributed among all generators; other possible mechanisms to handle these particular losses could be implemented, but they are beyond the main interest of the present paper.

2.2. Local marginal prices and nodal congestion prices

The solution of the OPF problem (2) provides the optimal operating point condition along with a set of Lagrangian multipliers and dual variables, which have been previously proposed as price indicators for OPF-based electricity markets [18]. Local marginal prices (LMPs) at each node are commonly associated with the Lagrangian multipliers of the power flow equations f . These LMPs can be decomposed in several terms, typically associated with bidding costs and dual variables (shadow prices) of system constraints. From (2) and (3), the following expressions for LMPs can be readily obtained:

$$\begin{aligned} \text{LMP}_{S_i} &= \rho_{P_{S_i}} = C_{S_i} + \mu_{P_{S_{\max_i}}} \\ &\quad - \mu_{P_{S_{\min_i}}} - \rho_{cP_{S_i}}(1 + \lambda_c + k_{G_c}) \\ \text{LMP}_{D_i} &= \rho_{P_{D_i}} = C_{D_i} + \mu_{P_{D_{\min_i}}} - \mu_{P_{D_{\max_i}}} - \rho_{cP_{D_i}}(1 + \lambda_c) \\ &\quad - \rho_{cQ_{D_i}}(1 + \lambda_c) \tan(\phi_{D_i}) - \rho_{Q_{D_i}} \tan(\phi_{D_i}) \end{aligned} \quad (4)$$

where ρ indicates Lagrangian multipliers of the power flow equations f , μ stands for the dual-variables (shadow prices) for the corresponding bid blocks, and ϕ_D are the demand power factors, which are assumed to be constant values. In (4), terms that depend on the loading parameter λ_c are not “standard”, and can be viewed as costs due to voltage stability constraints included in the power flow equations f_c [2].

Equations (4) can also be decomposed in order to determine nodal congestion prices (NCPs) [17], and are correlated to transmission line limits and hence define prices associated with the maximum loading condition or “system” available transfer capability, as discussed in Section 2.3. Using the de-

composition formula for LMPs proposed in [18], one has that:

$$\text{NCP} = \left(\frac{\partial f^T}{\partial y} \right)^{-1} \frac{\partial h^T}{\partial y} (\mu_{\max} - \mu_{\min}) \quad (5)$$

where y are the voltage phases (δ) and magnitudes (V), h represents the inequality constraint functions (e.g. transmission line currents), and μ_{\max} and μ_{\min} are the shadow prices associated with the inequality constraints.

2.3. System available transfer capability

The available transfer capability (ATC), as defined by NERC, is a “measure of the transfer capability remaining in the physical transmission network for further commercial activity over and above already committed uses” [22]. This basic concept is typically associated with “area” interchange limits used, for example, in markets for transmission rights. In [17], a “system-wide” ATC (SATC) is proposed to extend the ATC concept to a system domain, as follows:

$$\text{SATC} = \text{STTC} - \text{SETC} - \text{STRM} \quad (6)$$

where

$$\text{STTC} = \min(P_{\max_{I_{lim}}}, P_{\max_{V_{lim}}}, P_{\max_{S_{lim}}})$$

represents the “system-wide” total transfer capability, i.e. the maximum power that the system can deliver given the security constraints defined by thermal limits (I_{lim}), voltage limits (V_{lim}) and stability limits (S_{lim}) based on an $N - 1$ contingency criterion. SETC stands for the “system-wide” existing transmission commitments, and STRM is the “system-wide” transmission reliability margin, which is meant to account for uncertainties in system operations.

In this paper, the STTC is estimated based on the loading parameter λ_c included in the VSC-OPF problem (2), as follows:

$$\text{STTC} = (1 + \lambda_c)T \quad (7)$$

where T ($T = \sum_i P_{L_i}$) represents the total transaction level of the system. The SETC is defined as the actual power consumed by loads, i.e. $\text{SETC} = T$, and the STRM is assumed to be a fixed quantity, i.e. $\text{STRM} = K$, where K is a given MW value used to represent contingencies that are not being considered during the STTC computations (e.g. $N - 2$ contingency criteria). Thus the SATC for the VSC-OPF problem (2) can be defined as

$$\text{SATC} = \lambda_c T - K \quad (8)$$

3. Including contingencies in VSC-OPF market model

The solution of the VSC-OPF problem (2) is used as the initial condition for the two techniques proposed here to ac-

count for an $N - 1$ contingency criterion in electricity markets based on this type of OPF approach. Contingencies are included in (2) by taking out the selected lines when formulating the “critical” power flow equations f_c , thus ensuring that the current solution of the VSC-OPF problem is feasible also for the given contingency. Although one could solve one VSC-OPF for the outage of each line of the system, this would result in a lengthy process for realistic size networks. The techniques proposed in this paper address the problem of efficiently determining the contingencies which cause the worst effects on the system, i.e. the lowest SATC values.

3.1. Iterative method with $N - 1$ contingency criterion

Fig. 1 depicts the flow chart of the proposed method for including the $N - 1$ contingency criterion, based on the continuation power flow analysis, in the VSC-OPF-based market solutions. This method is basically composed of two basic steps.

- (1) An $N - 1$ contingency criterion is performed for determining the most critical line outage based on a continuation power flow analysis, using as generator and loading directions the supply and demand bids P_S and P_D determined from the last VSC-OPF solution. For the continuation power flow computations [20], system controls and limits are all considered to properly determine limit conditions due to voltage stability, thermal and/or bus voltage limits.
- (2) The line outage that causes the minimum SATC is selected and the power flow equations f_c are modified by taking out this critical line for the solution of the next VSC-OPF problem (2). The procedure stops when no “better” solution can be found, i.e. the SATC of the last two iterations is below certain tolerance, or when the continuation power flow yields the same line outage as the most severe one in the last two iterations. The latter criterion is used to avoid “cycling” problems.

Observe that the OPF-based solution of the power flow equations f_c and its associated SATC generally differ from the corresponding values obtained with the continuation power flow, since in the VSC-OPF problem control variables, such as generator voltages and reactive powers are modified in order to minimize costs and maximize the loading margin λ_c for the given contingency, hence the need for an iterative process.

When removing a line in equations f_c , it is necessary to consider the “system” effects of a line outage in order to avoid unfeasible conditions. For example, a line outage may cause the original grid to separate into two subsystems, i.e. islanding; in this case, the smallest island may be discarded, or just consider the associated contingency as “unfeasible” for the given operating conditions.

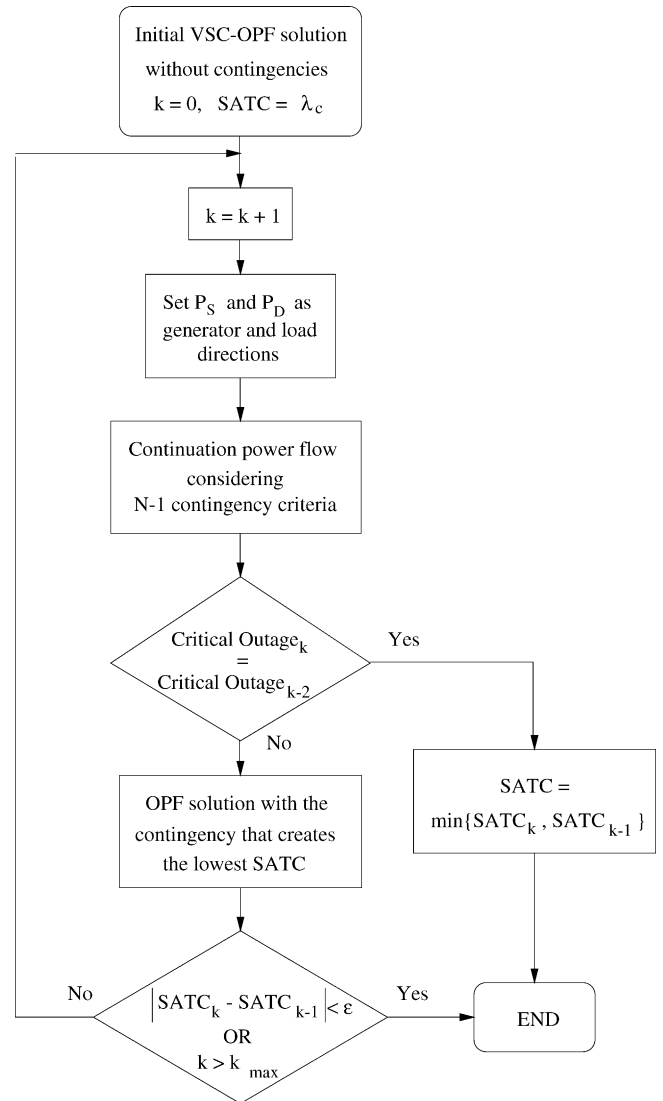

Fig. 1. Flow chart of the iterative method with $N - 1$ contingency criterion.

3.2. Multiple VSC-OPF with contingency ranking

This technique starts with a basic VSC-OPF solution that does not consider contingencies so that sensitivities of power flows with respect to the loading parameter λ_c can be computed. Then, based on this solution and assuming a small variation ϵ of the loading parameter, normalized sensitivity factors can be approximately computed as follows:

$$p_{ij} = P_{ij} \frac{\partial P_{ij}}{\partial \lambda_c} \approx P_{ij}(\lambda_c) \frac{P_{ij}(\lambda_c) - P_{ij}(\lambda_c - \epsilon)}{\epsilon} \quad (9)$$

where p_{ij} and P_{ij} are the sensitivity factor and the power flows of line $i-j$, respectively; this requires an additional solution of f_c for $\lambda_c - \epsilon$. The scaling is introduced for properly evaluating the “weight” of each line in the system, and thus consider only those lines characterized by both “significant” power transfers and high sensitivities [23,24].

The first “few” lines with the biggest sensitivity factors p_{ij} are selected (from multiple tests, five lines appear to be a sufficient number), and a VSC-OPF for each one of these contingencies is solved (may be done in parallel). The VSC-OPF solution that presents the lowest SATC is chosen as the final solution. Observe that not necessarily the outage of the line with the highest sensitivity factor will always produce the lowest SATC, because of the nonlinear nature of the voltage stability constraints in (2), hence the need for solving more than one VSC-OPF problem. Ranking the sensitivity factors leads generally to determine a reduced number of critical areas (SATCs associated with outages of high sensitivity lines within a certain area generally show only small differences); thus, in practice, one needs to evaluate only one contingency constrained VSC-OPF for each critical area identified by the sensitivity analysis.

Observe that line outages that cause a separation in islands of the original grid have to be treated in a special way, since the VSC-OPF (2) may not converge. In order to solve this problem, the market participants of the “smaller” islands are decommitted and the fixed power productions and/or absorptions eliminated. This solution appears to be reasonable, especially for realistic transmission grids, that are typically well interconnected, as generally only very few buses result islanded as a consequence of a line outage.

4. Examples

In this section, the VSC-OPF problem (2) and the proposed techniques to account for contingencies are applied to a 6-bus test system and to a 129-bus model of the Italian HV transmission system. The results of the optimization technique (1) are also discussed to observe the effect of the proposed method on LMPs, NCPs and system security, which is represented here through the SATC. The power flow limits needed in (1) were obtained “off-line”, as explained in Section 2, by means of a continuation power flow technique [20]. For both test systems, bid load and generator powers were used as the direction needed to obtain a maximum loading point and the associated power flows in the lines, so that proper comparisons with the proposed techniques can be made. All the results discussed here were obtained in MATLAB using a primal-dual IP method based on a Mehrotra’s predictor-corrector technique [25].

For both test cases, the limits of the loading parameter were assumed to be $\lambda_{c_{\min}} = 0.1$ and $\lambda_{c_{\max}} = 0.8$, i.e. it is assumed that the system can be securely loaded to an SATC between 10 and 80% of the total transaction level of the given solution. The weighting factor k in the objective function G of (2), used for maximizing the loading parameter, was set to $k = 10^{-4}$, as this was determined to be a value that does not significantly affect the market solution. Finally, the fixed value K used to represents the STRM is neglected ($K = 0$), as this does not really affect results obtained with the proposed techniques,

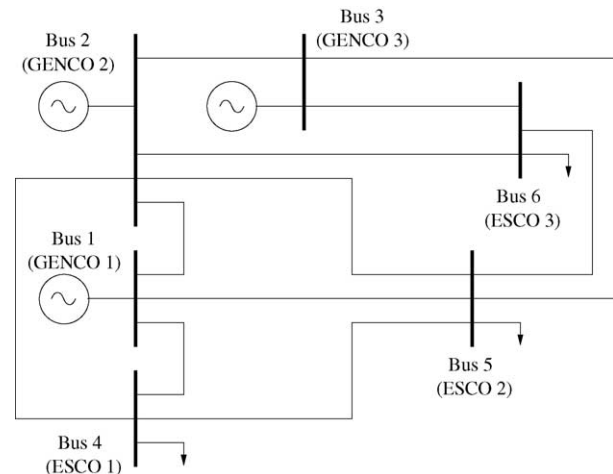

Fig. 2. 6-Bus test system.

since all computed values of SATC would be reduced by the same amount.

4.1. 6-Bus test case

Fig. 2 depicts the 6-bus test case, which is extracted from [26], representing three generation companies (GENCOs) and three energy supply companies (ESCOs) that provide supply and demand bids, respectively. (The complete data set for this system is provided in Appendix A, so that the results discussed here may be readily reproduced.)

Table 1 depicts the solution of (1), showing a low total transaction level T with respect to the maximum power limits of all bids, and heterogeneous LMPs and NCPs, indicating that system constraints, and in particular active power flow limits, negatively affect the market solution. The SATC value, which was computed off-line with the continuation power flow, seems to be consistent with the chosen power flow limits. Table 1 shows also the total losses and the payment given to the independent market operator (referred to as Pay_{IMO}), which is computed as the difference between demand and supply payments as follows:

$$\text{Pay}_{\text{IMO}} = \sum_i C_{S_i} P_{G_i} - \sum_i C_{D_i} P_{L_i} \quad (10)$$

Table 2 illustrates the initial solution of the VSC-OPF problem (2). Observe that, as expected, the absence of active power flow limits and contingencies makes possible a higher total transaction level T and more homogeneous LMPs and lower NCPs. For the sake of comparison, this table also depicts the value of the SATC obtained off-line for this particular operating conditions. Notice that this value is higher than the corresponding total transaction level T as well as the corresponding value in Table 1, which is to be expected, as “off-line” power flow limits on lines are not a very good representation of stability. This solution is used as the initial condition for the contingency analysis.

Table 1
6-Bus test system: OPF with off-line power flow limits

Participant	V (p.u.)	LMP (\$/MWh)	NCP (\$/MWh)	P_{BID} (MW)	P_0 (MW)	Pay (\$/h)
GENCO 1	1.1000	9.70	1.26	13.99	67.5	-790
GENCO 2	1.1000	8.45	0.00	0.00	103	-867
GENCO 3	1.1000	7.00	-1.50	20.55	45.0	-459
ESCO 1	1.0415	11.71	2.96	24.56	67.5	1078
ESCO 2	1.0431	10.36	1.60	2.31	75.0	799
ESCO 3	1.0575	9.51	0.88	6.60	67.5	704
Total	$T = 243.5$ MW Losses = 6.2 MW			Pay _{IMO} = 464 \$/h SATC = 0.3 MW		

Table 2
6-Bus test system: VSC-OPF without contingencies ($\lambda_{c_{\min}} = 0.1$)

Participant	V (p.u.)	LMP (\$/MWh)	NCP (\$/MWh)	P_{BID} (MW)	P_0 (MW)	Pay (\$/h)
GENCO 1	1.1000	9.16	-0.012	0.0	67.5	-618
GENCO 2	1.1000	9.06	0.00	37.5	103	-1270
GENCO 3	1.1000	9.15	0.029	30.0	45.0	-686
ESCO 1	1.0302	9.60	0.143	37.5	67.5	1008
ESCO 2	1.0313	9.60	0.172	15.0	75.0	864
ESCO 3	1.0526	9.39	0.131	11.9	67.5	745
Total	$T = 274.4$ MW Losses = 8.25 MW			Pay _{IMO} = 43.9 \$/h SATC = 19.1 MW		

Table 3 shows the coefficients p_{ij} used for the sensitivity analysis as well as the SATCs computed by means of the continuation power flows technique for the two steps required by the iterative method described in Section 3.1 when applying an $N - 1$ contingency criterion. Observe that both methods lead to similar conclusions, i.e. the sensitivity analysis indicates that the line 2–4 has the highest impact in the system power flows, while the $N - 1$ contingency criteria show that the outage of line 2–4 leads to the lowest SATC values.

Table 4 depicts the final VSC-OPF results for the critical line 2–4 outage. This solution presents practically the same total transaction level as provided by the solution without contingencies in Table 3, but with different demand side bidding, and a higher SATC, as expected, since the system is now optimized for the given critical contingency. Observe that the rescheduling of demand bids results also in slightly lower LMPs and NCPs, as a consequence of including more

Table 3
6-Bus test system: sensitivity coefficients p_{ij} and SATC determined applying an $N - 1$ contingency criterion for two iterations ($\lambda_{c_{\min}} = 0.1$)

Line $i-j$	$ P_{ij} $ (p.u.)	p_{ij}	SATC ¹ (MW)	SATC ² (MW)
1–2	0.0463	-0.0219	194.9	200.4
1–4	0.6768	0.3957	110.8	116.2
1–5	0.5263	0.3023	202.9	210.9
2–3	0.1208	0.1114	205.5	210.6
2–4	1.3872	0.8649	83.5	86.4
2–5	0.5100	0.3226	184.4	189.8
2–6	0.6211	0.4014	194.4	202.6
3–5	0.5487	0.3258	185.0	190.5
3–6	0.9591	0.5331	165.6	160.4
4–5	0.0351	0.0357	192.4	200.6
5–6	0.1031	0.0656	197.9	206.2

precise security constraints, which in turn results in a lower Pay_{IMO} value with respect to the one obtained with the standard OPF problem (1) in Table 1 (the higher losses are due the transaction level being higher).

The SATC in Table 4 corresponds to a $\lambda_{c_{\min}} = 0.1$, i.e. 10% of the total transaction level T , indicating that the current solution has the minimum required security level ($\lambda_c = \lambda_{c_{\min}} = 0.1$). For the sake of comparison, Table 5 depicts the final solution obtained with a different inferior limit for the loading parameter, i.e. $\lambda_{c_{\min}} = 0.125$. In this case, the line outage that creates the worst congestion problem is determined to be line 1–4. As expected, the higher minimum security margin leads to a lower T and, with respect to results reported in Table 4, also LMPs and NCPs are generally lower, which is due to the lower level of congestion of the current solution. Observe that a more secure solution leads to lower costs, because the demand model is assumed to be elastic; hence, higher stability margins lead to less congested, i.e. lower T , and “cheaper” optimal solutions.

In this example, the OPF technique does not reach a solution for $\lambda_{c_{\min}} > 0.15$, which means that a solution with at least 15% of security margin is not feasible when taking in account an $N - 1$ contingency criterion. Notice that it is not reasonable to set high values for $\lambda_{c_{\min}}$, since the resulting security margin already takes into account the most severe contingency, and is thus a conservative estimation of the system stability level.

4.2. 129-Bus Italian HV transmission system

Fig. 3 depicts the complete 129-bus 400 kV Italian transmission grid which is used here in order to discuss a more

Table 4
6-Bus test system: VSC-OPF with contingency on line 2–4 ($\lambda_{cmin} = 0.1$)

Participant	V (p.u.)	LMP (\$/MW h)	NCP (\$/MW h)	P_{BID} (MW)	P_0 (MW)	Pay (\$/h)
GENCO 1	1.1000	9.11	-0.013	0.0	67.5	-615
GENCO 2	1.1000	9.02	0.00	37.5	103	-1263
GENCO 3	1.1000	9.12	0.030	30.0	45.0	-684
ESCO 1	1.0312	9.55	0.139	36.0	67.5	989
ESCO 2	1.0313	9.56	0.170	15.0	75.0	860
ESCO 3	1.0518	9.35	0.133	13.3	67.5	756
Total	$T = 274.3$ MW Losses = 8.31 MW			$Pay_{IMO} = 43.4$ \$/h $SATC = 27.4$ MW		

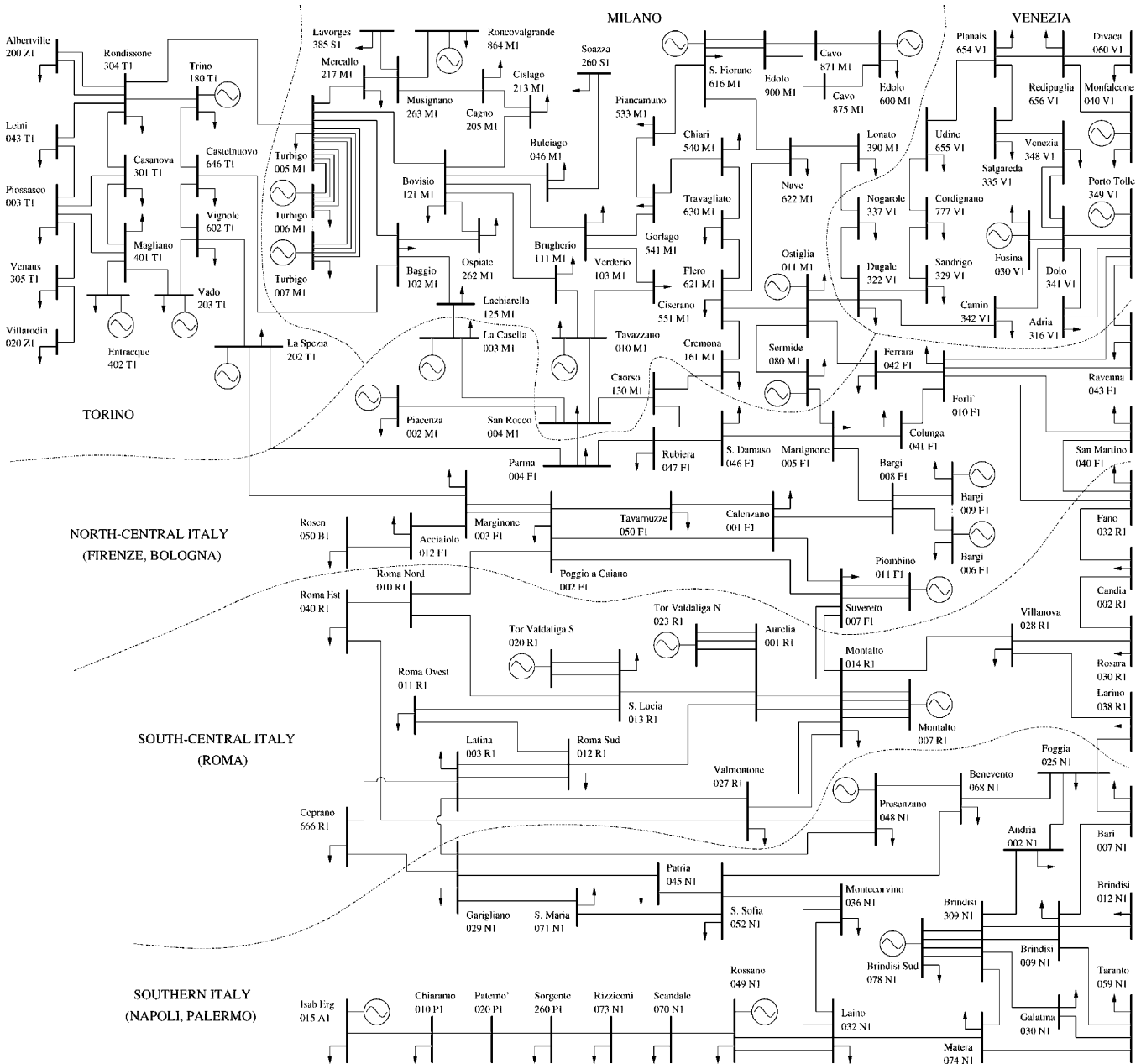

Fig. 3. 129-Bus Italian 400 kV transmission system (most of this information is publicly available at the GRTN web site <http://www.grtn.it>).

Table 5
6-Bus test system: VSC-OPF with contingency on line 1–4 ($\lambda_{c_{\min}} = 0.125$)

Participant	V (p.u.)	LMP (\$/MW h)	NCP (\$/MW h)	P_{BID} (MW)	P_0 (MW)	Pay (\$/h)
GENCO 1	1.1000	8.78	-0.046	0.0	67.5	-671
GENCO 2	1.1000	8.81	0.00	0.0	103	-1045
GENCO 3	1.1000	8.91	0.029	30.0	45.0	-722
ESCO 1	1.0490	9.15	0.082	0.0	67.5	670
ESCO 2	1.0276	9.33	0.152	11.3	75.0	898
ESCO 3	1.0431	9.18	0.137	19.3	67.5	880
Total	$T = 268.6$ MW Losses = 4.52 MW			Pay _{IMO} = 38.9 \$/h SATC = 33.6 MW		

Table 6
Comparison of different OPF-based methods for the Italian system example

OPF method	Critical contingency	T (GW)	SATC (GW)	Losses (MW)	Pay _{GRTN} (\$/MW h)
OPF (1)	“Off-line” power flows	19.8	0.04	85.6	21900
VSC-OPF (2)	None	20.8	1.6	96.2	3210
Iterative VSC-OPF	Turbigo-Bovisio	20.6	2.1	95.2	3180
VSC-OPF with sensitivity analysis	Turbigo-Baggio	20.6	2.4	95.2	3180

realistic test case and to better test the proposed techniques. It has been assumed that 32 generators and 82 consumers participate in the market auction. Usually, Italy imports about the 10% of its power demand from France and Switzerland, hence power supply bids were assumed at the interties.

All bids were based on prices around 30–40 US\$/MW h, which are the average prices over the last few years in other European countries where electricity markets are currently in operation, and it also considers actual operating costs of thermal plants (55% of the electrical energy produced in Italy is thermal). Power bid levels were chosen to be about 30% of the average consumption in order to force system congestion. All system data and security constraints, i.e. voltage limits, generation reactive power limits and transmission line

thermal limits, were provided by CESI, the Italian electrical research center.

Table 6 depicts the total results for different OPF problem solutions, i.e. the standard OPF with “off-line” power transfer limits, the VSC-OPF without contingencies and the final results obtained with the proposed techniques for including the worst contingency, which was determined to be the outage of lines in the Milano area (buses Turbigo, Bovisio and Baggio) by both the $N - 1$ contingency criterion and the sensitivity analysis. Conclusions similar to what is observed for the 6-bus example can be drawn, i.e. the proposed techniques yield a higher total transmission level T and a better SATC value, while reducing the payment to the Italian independent market operator GRTN (Gestore Rete Trasmissione Nazionale). Observe that the iterative method and the sensitivity-based technique yield two different critical lines, but provide practically identical results, as the two lines are in the same critical area, i.e. Milano. (The security constrained OPF solutions of (2) show a total loss increase, since the transaction level also increases.)

Fig. 4 depicts the comparison of LMPs and NCPs obtained with the standard and the VSC-OPF for an outage of the Turbigo-Baggio line, confirming that a proper representation of voltage stability constraints and worst-case contingency result in a better distribution of costs (LMPs) and in a reduced impact of system congestion on electricity prices (NCPs).

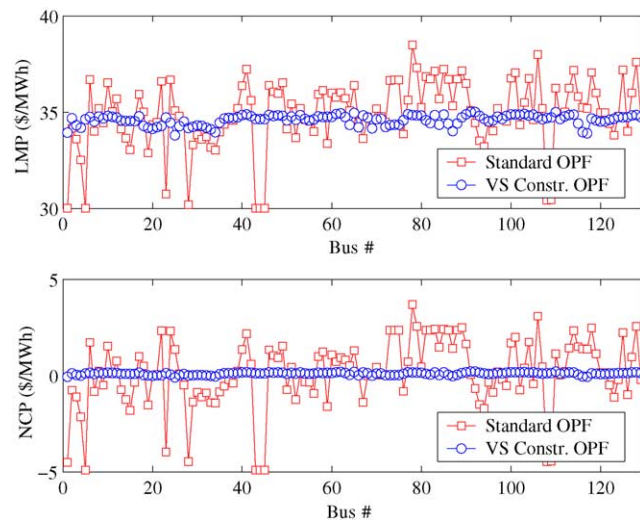

Fig. 4. Comparison between LMPs and NCPs obtained with the standard and the VSC-OPF with contingency on the Turbigo-Baggio line for the Italian system example.

5. Conclusions

In this paper, two methods for including contingencies in a VSC-OPF-based market are proposed and tested on a simple test system as well as on a realistic network. Comparisons between the results obtained with the proposed techniques and those obtained by means of a “standard” OPF-based market

Table A.1
GENCO and ESCO bids and bus data for the 6-bus test system

Participant	C (\$/MWh)	P_{\max} (MW)	P_{L_0} (MW)	Q_{L_0} (MVar)	P_{G_0} (MW)	$Q_{G_{\lim}}$ (MVar)
GENCO 1	9.7	30	0	0	67.5	± 150
GENCO 2	8.8	37.5	0	0	103	± 150
GENCO 3	7.0	30	0	0	45	± 150
ESCO 1	12.0	37.5	67.5	45	0	0
ESCO 2	10.5	15	75	52.5	0	0
ESCO 3	9.5	30	67.5	45	0	0

model indicate that a proper representation of system security and a proper inclusion of contingencies result in improved transactions, higher security margins and lower prices.

The two proposed techniques lead to similar solutions using different strategies. The first method tries to define the worst-case contingency by determining the lowest SATC, while the second approach computes sensitivity factors whose magnitude indicate which line outages maximally affect the total transaction level and system security.

Further research work will concentrate in modifying the proposed VSC-OPF techniques to account for other system constraints, such as power reserves, minimum power bids and minimum up and down times for generators.

Acknowledgements

The authors wish to thank Dr. M. Pozzi and Mr. A. Danelli from CESI for providing the Italian system data and for their helpful comments.

Appendix A. Data of the 6-bus system example

This section depicts the complete data set for the 6-bus test system of Fig. 2. Table A.1 shows supply and demand bids and the bus data for the market participants, whereas Table A.2 shows the line data. Maximum active power flow limits were computed off-line using a continuation power flow with generation and load directions based on the corresponding power bids, whereas thermal limits were assumed to be twice the values of the line currents at base load condi-

Table A.2
Line data for the 6-bus test system

Line $i-j$	R_{ij} (p.u.)	X_{ij} (p.u.)	$B_i/2$ (p.u.)	P_{\max} (MW)	I_{\max} (A)
1–2	0.1	0.2	0.02	11.74	200
1–4	0.05	0.2	0.02	39.84	200
1–5	0.08	0.3	0.03	50.44	200
2–3	0.05	0.25	0.03	18.27	200
2–4	0.05	0.1	0.01	57.69	200
2–5	0.1	0.3	0.02	33.11	200
2–6	0.07	0.2	0.025	43.32	200
3–5	0.12	0.26	0.025	23.04	200
3–6	0.02	0.1	0.01	47.45	200
4–5	0.2	0.4	0.04	7.73	200
5–6	0.1	0.3	0.03	2.19	200

tions for a 400 kV voltage rating. In Table A.2, it is assumed that $I_{ij_{\max}} = I_{ji_{\max}} = I_{\max}$ and $P_{ij_{\max}} = P_{ji_{\max}} = P_{\max}$. Maximum and minimum voltage limits are considered to be 1.1 and 0.9 p.u.

References

- [1] W. Rosehart, C.A. Cañizares, V. Quintana, Costs of voltage security in electricity markets, Proceedings of the 2001 IEEE-PES Summer Meeting, Seattle, WA, USA, 2000.
- [2] F. Milano, C.A. Cañizares, M. Invernizzi, Multi-objective optimization for pricing system security in electricity markets, IEEE Trans. Power Syst. 18 (2) (2003) 596–604.
- [3] M. Huneault, F.D. Galiana, A survey of the optimal power flow literature, IEEE Trans. Power Syst. 6 (2) (1991) 762–770.
- [4] G.D. Irisarri, X. Wang, J. Tong, S. Mokhtari, Maximum loadability of power systems using interior point nonlinear optimization method, IEEE Trans. Power Syst. 12 (1) (1997) 162–172.
- [5] C.A. Cañizares, Applications of optimization to voltage collapse analysis, Proceedings of the IEEE-PES Summer Meeting, San Diego, USA, 1998.
- [6] C.A. Cañizares, W. Rosehart, A. Berizzi, C. Bovo, Comparison of voltage security constrained optimal power flow techniques, Proceedings of the 2001 IEEE-PES Summer Meeting, Vancouver, BC, Canada, 2001.
- [7] M. Madrigal, V.H. Quintana, Optimal day-ahead network-constrained power system's market operations planning using an interior point method Proceedings of the IEEE Canadian Conference on Electrical and Computer Engineering, vol. 1, 1998, pp. 388–401.
- [8] M. Madrigal, Optimization model and techniques for implementation and pricing of electricity markets, Ph.D. thesis, University of Waterloo, Waterloo, Ont., Canada, 2000.
- [9] O. Alsaç, B. Stott, Optimal load flow with steady-state security, IEEE Trans. Power Syst. PAS-93 (3) (1974) 745–751.
- [10] O. Alsaç, J. Bright, M. Prais, B. Stott, Further developments in LP-based optimal power flow, IEEE Trans. Power Syst. 5 (3) (1990) 697–711.
- [11] M. Rodrigues, O.R. Saavedra, A. Monticelli, Asynchronous programming model for the concurrent solution of the security constrained optimal power flow problem, IEEE Trans. Power Syst. 9 (4) (1994) 2021–2027.
- [12] F. Xia, A.P.S. Meliopoulos, A methodology for probabilistic transfer capability analysis, IEEE Trans. Power Syst. 11 (3) (1996) 1269–1278.
- [13] V.C. Ramesh, X. Li, A fuzzy multiobjective approach to contingency constrained OPF, IEEE Trans. Power Syst. 12 (3) (1997) 1348–1354.
- [14] F. Capitanescu, T.V. Cutsem, Preventive control of voltage security margins: a multicontingency sensitivity-based approach, IEEE Trans. Power Syst. 17 (2) (2002) 358–364.
- [15] E.E. El-Araby, N. Yorino, H. Sasaki, H. Sugihara, A hybrid genetic algorithm/SLP for voltage stability constrained VAR planning problem, Proceedings of the Bulk Power systems Dynamics and Control-V, Onomichi, Japan, 2001.

- [16] C.A. Cañizares, H. Chen, W. Rosehart, Pricing system security in electricity markets, Proceedings of the Bulk Power Systems Dynamics and Control-V, Onomichi, Japan, 2001.
- [17] H. Chen, Security cost analysis in electricity markets based on voltage security criteria and web-based implementation, Ph.D. thesis, University of Waterloo, Waterloo, ON, Canada, 2002.
- [18] K. Xie, Y.-H. Song, J. Stonham, E. Yu, G. Liu, Decomposition model and interior point methods for optimal spot pricing of electricity in deregulation environments, *IEEE Trans. Power Syst.* 15 (1) (2000) 39–50.
- [19] B.S. Gisin, M.V. Obessis, J.V. Mitsche, Practical methods for transfer limit analysis in the power industry deregulated environment, Proceedings of the PICA IEEE International Conference, 1999, pp. 261–266.
- [20] C.A. Cañizares (Ed.), Voltage Stability Assessment: Concepts, Practices and Tools, Technical Report, IEEE/PES Power System Stability Subcommittee, SP101PSS, August 2002.
- [21] W. Rosehart, C.A. Cañizares, V.H. Quintana, Multi-objective optimal power flows to evaluate voltage security costs, *IEEE Trans. Power Syst.* 18 (2) (2003) 578–587.
- [22] Available transfer capability definition and determination, Technical Report, NERC, USA, 1996.
- [23] C.A. Cañizares, Z.T. Faur, Analysis of SVC and TCSC controllers in voltage collapse, *IEEE Trans. Power Syst.* 14 (1) (1999) 158–165.
- [24] C. A. Cañizares, M. Pozzi, FACTS controllers performance and influence on voltage control in the presence of secondary voltage regulation, Technical Report, CESI, RETE-A0/021456, Milan, Italy, June 2000, 66 pp.
- [25] V.H. Quintana, G.L. Torres, Introduction to interior-point methods, IEEE PICA, Santa Clara, CA, 1999.
- [26] G.B. Sheblé, Computational Auction Mechanism for Restructured Power Industry Operation, Kluwer Academic Publishers, Boston, 1998.