

# Congestion Management Ensuring Voltage Stability

Antonio J. Conejo, *Fellow, IEEE*, Federico Milano, *Member, IEEE*, and Raquel García-Bertrand, *Member, IEEE*

**Abstract**—This paper addresses the congestion management problem avoiding offline transmission capacity limits related to stability. These limits on line power flows are replaced by optimal power flow-related constraints that ensure an appropriate level of security, mainly targeting voltage instabilities, which are the most common source of stability problems. Results from an illustrative case study based on the IEEE 24-bus Reliability Test System are analyzed. Conclusions are duly drawn.

**Index Terms**—Congestion management, nonlinear programming, transmission capacity.

## NOTATION

The notation used throughout the paper is stated below for quick reference. Note that “ $\hat{\cdot}$ ” indicates security loading condition.

### A. Functions

$h_m(\cdot)$	Active power flow through line $m$ as a function of voltage angles.
$I_m(\cdot)$	Current magnitude through line $m$ as a function of voltage magnitudes and angles.
$p_n^\theta(\cdot)$	Active power injection in node $n$ as a function of voltage angles.
$p_n(\cdot)$	Active power injection in node $n$ as a function of voltage magnitudes and angles.
$q_n(\cdot)$	Reactive power injection in node $n$ as a function of voltage magnitudes and angles.

### B. Variables

$\hat{k}_G$	Scalar variable used to represent system losses associated with the security loading condition.
$P_{Di}$	Final active power consumption of demand $i$ .
$P_{Dn}$	Total active final consumption in node $n$ .
$P_{Gj}$	Final active power production of generator $j$ .
$P_{Gn}$	Total final active production in node $n$ .
$Q_{Di}$	Final reactive power consumption of demand $i$ .
$Q_{Gj}$	Final reactive power production of generator $j$ .
$V$	Vector of node voltage magnitudes.
$\Delta P_{Di}^{\text{down}}$	Active power decrement in demand $i$ due to congestion management.

$\Delta P_{Di}^{\text{up}}$	Active power increment in demand $i$ due to congestion management.
$\Delta P_{Gj}^{\text{down}}$	Active power decrement in generator $j$ due to congestion management.
$\Delta P_{Gj}^{\text{up}}$	Active power increment in generator $j$ due to congestion management.
$\theta$	Vector of node voltage angles.
$\lambda$	Loading margin.

### C. Constants

$I_{TH,m}^{\text{max}}$	Maximum current magnitude in line $m$ .
$P_{Di}^A$	Active power consumed by demand $i$ as determined by the market-clearing procedure.
$P_{Gj}^A$	Active power produced by generator $j$ as determined by the market-clearing procedure.
$P_{Di}^{\text{max}}$	Maximum power to be supplied to demand $i$ .
$P_{Di}^{\text{min}}$	Minimum power to be supplied to demand $i$ .
$P_{Gj}^{\text{max}}$	Maximum power output of generator $j$ .
$P_{Gj}^{\text{min}}$	Minimum power output of generator $j$ .
$P_{ST,m}^{\text{max}}$	Offline stability capacity limit of line $m$ (active power).
$P_{TH,m}^{\text{max}}$	Thermal capacity limit of line $m$ (active power).
$Q_{Gj}^{\text{max}}$	Reactive power capacity of generator $j$ .
$Q_{Gj}^{\text{min}}$	Minimum reactive power production of generator $j$ .
$r_{Di}^{\text{down}}$	Price offered by demand $i$ to decrease its pool power schedule for congestion management purposes.
$r_{Di}^{\text{up}}$	Price offered by demand $i$ to increase its pool power schedule for congestion management purposes.
$r_{Gj}^{\text{down}}$	Price offered by generator $j$ to decrease its pool power schedule for congestion management purposes.
$r_{Gj}^{\text{up}}$	Price offered by generator $j$ to increase its pool power schedule for congestion management purposes.
$\tan(\phi_{Di})$	Power factor of demand $i$ .
$V_n^{\text{max}}$	Maximum voltage magnitude in node $n$ .
$V_n^{\text{min}}$	Minimum voltage magnitude in node $n$ .
$\lambda_{\text{min}}$	Minimum value for $\lambda$ .

### D. Sets

$\mathcal{D}$	Set of indices of demands.
$\mathcal{D}_n$	Set of indices of demands located in node $n$ .
$\mathcal{G}$	Set of indices of online generators.
$\hat{\mathcal{G}}$	Set of indices of online generators for the security loading condition.
$\mathcal{G}_n$	Set of indices of online generators located in node $n$ .
$\mathcal{N}$	Set of indices of all nodes.
$\Omega$	Set of indices of transmission lines.

Manuscript received December 27, 2004; revised September 6, 2005. The authors are supported in part by the Ministry of Science and Technology of Spain under CICYT Project DPI2003-01362 and in part by the Junta de Comunidades de Castilla-La Mancha under Project GC-02-006. Paper no. TPWRS-00674-2004.

The authors with the Department of Electrical Engineering, University of Castilla-La Mancha, Ciudad Real, Spain (e-mail: Antonio.Conejo@uclm.es; Federico.Milano@uclm.es; Raquel.Garcia@uclm.es).

Digital Object Identifier 10.1109/TPWRS.2005.860910

## I. INTRODUCTION

**T**HIS paper considers a day-ahead electric energy market based on a pool. Within this pool, producers and retailers/consumers submit production and consumption bids to the market operator, which, in turn, clears the market using an appropriate market-clearing procedure. This procedure results in 24 hourly energy prices to be paid by consumers and to be charged by producers [1], [2].

More often than not, pool market results originate network congestion problems, and the independent system operator (ISO) should determine the minimal changes in the market results that ensure a secure operation. We assume that the ISO has the appropriate regulatory power to enforce the required production and consumption changes, which is the case for most European ISOs.

Usually, congestion management consists in enforcing transmission capacity limits that are computed offline to ensure stability conditions that render a secure operation. This enforcement results in generation/consumption changes for generators and demands. Thermal transmission capacity limits are also enforced, but usually they are less restrictive than offline stability limits.

We propose a formulation that guarantees a secure operation and includes only thermal limits on transmission lines, thus not using artificial stability limits on transmission lines that are typically computed offline. To ensure a secure operation, the congestion-relieving algorithm includes online conditions based on the power flow equations that guarantee not only a stable operating point but also a minimum required distance to voltage collapse conditions [3], [4]. It should be noted that transient and frequency stability conditions are not considered in this paper as voltage stability is usually the most restrictive stability condition in the considered time frame.

We consider that both producers and consumers may equally alter their power schedules (as determined by the market-clearing procedure) to contribute to congestion management. In other words, both producers and consumers bid to alter their respective productions/consumptions in the congestion management procedure.

The main contribution of this paper is to show that using voltage stability constraints in a congestion-relieving algorithm results normally in better economic outcomes (for consumers and producers) than using offline nonthermal line capacity limits. We believe this is an important contribution as standard congestion-relieving procedures do use generally offline nonthermal capacity constraints and might render safe but uneconomical solutions.

It should be noted that [4] provides a multiobjective market-clearing procedure, while this paper provides a congestion management technique to be used once the market has been cleared. Moreover, [4] does not allow a direct computation of marginal prices as the objective function is neither a cost nor a social welfare, while the technique used in this paper, if applied to the market-clearing problem, allows obtaining directly marginal prices. Furthermore, this paper enforces voltage security constraints without resorting to a rather artificial multiobjective criterion, which constitutes a clear advantage over [4]. Finally, most technical references pertaining to voltage stability (e.g.,

[3] and [4]) do not consider generation limits while computing grid-induced voltage stability limits; however, we have included an iterative mechanism to take into account how the generation limits affect the network loadability.

A case study based on the IEEE 24-bus Reliability Test System (IEEE RTS) is used to illustrate the functioning of the proposed congestion-relieving procedure and to compare it with procedures that impose offline bounds on transmission line flows.

Relevant references on congestion management include, among others, [5]–[9]. Reference [5] provides an insightful tutorial on congestion management. References [6] and [7] provide the perspective of a particular ISO on congestion management issues. Reference [9] provides a detailed analysis of different congestion management techniques used in different electricity markets throughout the world and a general congestion-relieving algorithm similar to the one described in Section II-B.

Background on electricity markets can be found in [10]–[14].

The rest of this paper is organized as follows. Section II provides a description of the market-clearing procedure, the formulation of the classical congestion-relieving algorithm, as well as the one proposed in this paper. The solution procedure of both algorithms is described. Section III provides economics efficiency metrics to appraise the impact of congestion management on the market performance for both algorithms. Section IV presents result for the IEEE RTS obtained using both a classical congestion management procedure and the one proposed in this paper. Section V summarizes some relevant conclusions.

## II. FORMULATION AND SOLUTION

### A. Market-Clearing Procedure

This paper considers a day-ahead electric energy market based on a pool. Within this pool, producers and consumers submit production and consumption bids to the market operator, which clears the market using an appropriate market-clearing procedure [1], [2]. For each hour, the bid of each producer is monotonously increasing piecewise constant stacks of quantities and prices. Analogously, the bid of each consumer is monotonously decreasing piecewise constant stacks of quantities and prices. The market-clearing procedure results in 24 hourly energy prices to be paid by consumers and to be charged by producers. It should be noted that while the time framework for the day-ahead electric energy market is 24 hours, the time framework for congestion management is 1 hour, as congestion-relieving actions are considered hour by hour.

For any given hour, the resulting production of each producer is denoted by  $P_{G_j}^A$  and the consumption of each consumer by  $P_{D_i}^A$ .

### B. Classical Congestion Management

The classical congestion-relieving problem can be formulated as follows:

$$\begin{aligned} \text{Minimize } & \sum_{j \in \mathcal{G}} \left( r_{G_j}^{\text{up}} \Delta P_{G_j}^{\text{up}} + r_{G_j}^{\text{down}} \Delta P_{G_j}^{\text{down}} \right) \\ & + \sum_{i \in \mathcal{D}} \left( r_{D_i}^{\text{up}} \Delta P_{D_i}^{\text{up}} + r_{D_i}^{\text{down}} \Delta P_{D_i}^{\text{down}} \right) \end{aligned} \quad (1)$$

$$\text{subject to } P_{Gn} - P_{Dn} = p_n^\theta(\theta), \quad \forall n \in \mathcal{N} \quad (2)$$

$$P_{Gj}^{\min} \leq P_{Gj} \leq P_{Gj}^{\max}, \quad \forall j \in \mathcal{G} \quad (3)$$

$$P_{Di}^{\min} \leq P_{Di} \leq P_{Di}^{\max}, \quad \forall i \in \mathcal{D} \quad (4)$$

$$|h_m(\theta)| \leq P_{TH,m}^{\max}, \quad \forall m \in \Omega \quad (5)$$

$$|h_m(\theta)| \leq P_{ST,m}^{\max}, \quad \forall m \in \Omega \quad (6)$$

and

$$P_{Gj} = P_{Gj}^A + \Delta P_{Gj}^{\text{up}} - \Delta P_{Gj}^{\text{down}}, \quad \forall j \in \mathcal{G} \quad (7)$$

$$P_{Di} = P_{Di}^A + \Delta P_{Di}^{\text{up}} - \Delta P_{Di}^{\text{down}}, \quad \forall i \in \mathcal{D} \quad (8)$$

and  $\forall n \in \mathcal{N}$

$$P_{Gn} = \sum_{j \in \mathcal{G}_n} P_{Gj}, \quad P_{Dn} = \sum_{i \in \mathcal{D}_n} P_{Di} \quad (9)$$

and

$$\Delta P_{Gj}^{\text{up}}, \quad \Delta P_{Gj}^{\text{down}} \geq 0, \quad \forall j \in \mathcal{G} \quad (10)$$

$$\Delta P_{Di}^{\text{up}}, \quad \Delta P_{Di}^{\text{down}} \geq 0, \quad \forall i \in \mathcal{D}. \quad (11)$$

Notice that  $P_{Gj}^A$  and  $P_{Di}^A$  are obtained from market-clearing mechanism and are thus constant powers in (7) and (8). In (1)–(11), the network is represented by means of a dc model, as it is common practice for the congestion management problem [7]. Thus, voltages are supposed to be equal to 1 p.u. in all buses, and reactive powers are not considered in this formulation.

Equation (1), the objective function, is the cost incurred in up/down power adjustments by the ISO to ensure a secure operation. We consider that any change from the market-clearing conditions implies a payment to the agent involved. Note that other settlement arrangements are possible, as for instance, the ones used in [9]. Equations (2) represent power balances in all nodes of the considered network. Function  $p_i^\theta(\theta)$  is the active power injection in node  $i$  as a function of voltage angles. That is,  $p_i^\theta(\theta) = \sum_{j \in \mathcal{N}} [G_{ij} \cos(\delta_i - \delta_j) + B_{ij} \sin(\delta_i - \delta_j)]$ , where  $G_{ij}$  and  $B_{ij}$  are, respectively, the real and imaginary part of the element  $ij$  of the nodal admittance matrix. Equations (3) and (4) enforce maximum and minimum production/consumption bounds for generators/demands. Equations (5) are thermal capacity limits of the transmission lines, while (6) are offline stability capacity limits of the lines. Function  $h_m(\theta)$  is the power flow through line  $m$  connecting nodes  $i$  and  $j$  as a function of voltage angles. That is,  $h_m(\theta) = G_{ij}(\cos(\delta_i - \delta_j) - 1) + B_{ij} \sin(\delta_i - \delta_j)$ . Equations (7) and (8) express final powers are a function of market results and power increments/decrements to achieve a secure operation. Equations (9) transfer generator or demand values to node values. Equations (10) and (11) declare that power increments/decrements are positive.

In this paper, we propose to substitute offline constraints (6) for other physically based constraints, which are directly related with the current operating conditions of the system. Additionally, we do not consider voltage magnitudes equal to one, and we do take into account reactive power flows. The resulting formulation is stated in the next subsection.

### C. No Limits on Lines Other Than Physical Ones

The proposed congestion-relieving problem is formulated in the following. We would like to point out that we do compare

the proposed technique with the dc model (1)–(11) because such model is commonly used in practice for congestion relieving, as stated in the worldwide survey reported in [7]. Security is ensured enforcing adequate voltage behavior for a loading condition (security loading condition) higher than the current one as determined by the margin  $\lambda$ . This criterion is based on [3] and [4]. The proposed congestion-relieving problem is

$$\begin{aligned} \text{Minimize } & \sum_{j \in \mathcal{G}} \left( r_{Gj}^{\text{up}} \Delta P_{Gj}^{\text{up}} + r_{Gj}^{\text{down}} \Delta P_{Gj}^{\text{down}} \right) \\ & + \sum_{i \in \mathcal{D}} \left( r_{Di}^{\text{up}} \Delta P_{Di}^{\text{up}} + r_{Di}^{\text{down}} \Delta P_{Di}^{\text{down}} \right) \end{aligned} \quad (12)$$

$$\text{subject to } P_{Gn} - P_{Dn} = p_n(V, \theta), \quad \forall n \in \mathcal{N} \quad (13)$$

$$\hat{P}_{Gn} - \hat{P}_{Dn} = \hat{p}_n(\hat{V}, \hat{\theta}), \quad \forall n \in \mathcal{N} \quad (14)$$

$$Q_{Gn} - Q_{Dn} = q_n(V, \theta), \quad \forall n \in \mathcal{N} \quad (15)$$

$$\hat{Q}_{Gn} - \hat{Q}_{Dn} = \hat{q}_n(\hat{V}, \hat{\theta}), \quad \forall n \in \mathcal{N} \quad (16)$$

$$Q_{Di} = P_{Di} \tan(\phi_{Di}), \quad \forall i \in \mathcal{D} \quad (17)$$

$$P_{Gj}^{\min} \leq P_{Gj} \leq P_{Gj}^{\max}, \quad \forall j \in \mathcal{G} \quad (18)$$

$$P_{Di}^{\min} \leq P_{Di} \leq P_{Di}^{\max}, \quad \forall i \in \mathcal{D} \quad (19)$$

$$Q_{Gj}^{\min} \leq Q_{Gj} \leq Q_{Gj}^{\max}, \quad \forall j \in \mathcal{G} \quad (20)$$

$$Q_{Gj}^{\min} \leq \hat{Q}_{Gj} \leq Q_{Gj}^{\max}, \quad \forall j \in \mathcal{G} \quad (21)$$

$$V_n^{\min} \leq V_n \leq V_n^{\max}, \quad \forall n \in \mathcal{N} \quad (22)$$

$$V_n^{\min} \leq \hat{V}_n \leq V_n^{\max}, \quad \forall n \in \mathcal{N} \quad (23)$$

$$I_m(V, \theta) \leq I_{TH,m}^{\max}, \quad \forall m \in \Omega \quad (24)$$

$$\hat{I}_m(\hat{V}, \hat{\theta}) \leq I_{TH,m}^{\max}, \quad \forall m \in \Omega \quad (25)$$

and

$$\lambda \geq \lambda_{\min}, \quad \lambda \in \mathbb{R} \quad (26)$$

$$\hat{P}_{Gj} = (1 + \lambda + \hat{k}_G) P_{Gj}, \quad \forall j \in \hat{\mathcal{G}} \quad (27)$$

$$\hat{P}_{Di} = (1 + \lambda) P_{Di}, \quad \forall i \in \mathcal{D} \quad (28)$$

$$\hat{Q}_{Di} = (1 + \lambda) Q_{Di}, \quad \forall i \in \mathcal{D} \quad (29)$$

and  $\forall n \in \mathcal{N}$

$$\hat{P}_{Gn} = \sum_{j \in \mathcal{G}_n} \hat{P}_{Gj}, \quad \hat{P}_{Dn} = \sum_{i \in \mathcal{D}_n} \hat{P}_{Di} \quad (30)$$

$$Q_{Gn} = \sum_{j \in \mathcal{G}_n} Q_{Gj}, \quad Q_{Dn} = \sum_{i \in \mathcal{D}_n} Q_{Di} \quad (31)$$

$$\hat{Q}_{Gn} = \sum_{j \in \mathcal{G}_n} \hat{Q}_{Gj}, \quad \hat{Q}_{Dn} = \sum_{i \in \mathcal{D}_n} \hat{Q}_{Di} \quad (32)$$

and constraints (7)–(11).

The objective function (12) is similar to the objective function (1). Constraints (13) and (14) are active power balances in all nodes for the current and security loading conditions, respectively. Constraints (15) and (16) are reactive power balances in all nodes for the current and security loading conditions, respectively. Constraints (17) relate reactive and active power demands considering a constant power factor. Constraints (18) enforce bounds on the active power productions of generators, while constraints (19) enforce bounds on the consumptions of demands. As it is customary in voltage stability analysis, bounds (19) are not considered for the security loading condition, as these conditions are not actual operating conditions. Constraints (20) and (21) enforce bounds on the reac-

tive power production of generators for current and security loading conditions, respectively. Constraints (22) and (23) establish bounds on voltage magnitudes for current and security loading conditions, respectively. Constraints (24) and (25) establish bounds on actual magnitudes through lines for actual and security loading conditions, respectively. Constraint (26) states that the current value of  $\lambda$  is above a pre-specified minimum value, thereby guaranteeing an appropriate distance from the current operating point to the voltage collapse or the closest operating limit. Constraints (27)–(29) relate current and security loading conditions. Finally, constraints (30)–(32) relate generator or demand magnitudes with node magnitudes.

Note that (13)–(16) are the standard power flow equations; thus, active and reactive power losses are properly taken into account in the model. Furthermore, the variable  $k_G$ , which is included in (27), is used to enforce the fact that power flow (13) and (15), and the security power flow (14) and (16), are linearly related in terms of active power (through the loading margin  $\lambda$ ), while losses are not. Thus, variable  $k_G$  represents unknown losses for the security power flow (14) and (16). Assuming that (27) has been written for all generators  $j \in \hat{\mathcal{G}}$ , the variable  $k_G$  is balanced by the phase reference angle. On the other hand, reactive power losses are balanced by two independent sets of generator reactive powers variables, which are defined for (13) and (15), and for (14) and (16), respectively.

Constraints (14), (16), (21), (23), and (25)–(29) are similar to what was proposed in [3] and [4]. However, while in [3] and [4],  $\lambda$ 's associated with a critical loading condition, in the problem (12)–(32) and (7)–(11), it is only required that the current solution exhibits at least a minimum security level ( $\lambda \geq \lambda_{\min}$ ). Observe that fixing the minimum value of the loading margin  $\lambda$  can lead to infeasible solutions for high values of  $\lambda_{\min}$ . However, it is assumed that the problem has a solution at least for  $\lambda_{\min} = 0$ , at which the proposed method reduces to a standard optimal power flow (OPF) problem, basically similar to (1)–(11), except for the  $P_{ST,m}^{\max}$  limits.

It should be noted that we consider not only how network constraints (voltage stability constraints) affect rescheduling but also the other way round, i.e., how the generation limits affect the network loadability. It is possible to include these limits at the cost of solving several times the voltage stability constrained OPF model. At this aim, in (27), the set  $\hat{\mathcal{G}}$  refers to all generators that comply with the following constraints:

$$P_{G_j}^{\min} \leq \hat{P}_{G_j} \leq P_{G_j}^{\max}, \quad \forall j \in \hat{\mathcal{G}}. \quad (33)$$

All  $\hat{P}_{G_j}$  that are out of their limits are fixed to the corresponding maximum or minimum limit. Observe that (33) is verified off-line. If some generators do not comply with (33), the set  $\hat{\mathcal{G}}$  is updated and the OPF repeated. The process stops once the solution verifies (33). In all case studies that we have considered, the proposed technique took two to four iterations to converge.

Observe that (33) cannot be included directly in the OPF problem because the loading margin  $\lambda$  multiplies all generator and load powers. These powers are used as “directions” to get the maximum security loading condition (MSLC). Including generator limits in the MSLC constraints would lead to the following inconsistent result:  $\lambda$  could not be greater than 0 if just one generator capacity limit were binding ( $P_{G_j} = P_{G_j}^{\max}$ ). This

result is clearly not realistic as the network is not at its maximum loading condition for  $\lambda = 0$ .

We would like to point out that most technical references pertaining to voltage stability (e.g., [3] and [4]) do not consider generation limits while computing grid-induced voltage stability limits. Thus, taking into account these limits is a new contribution of the present paper.

It is important to note that the proposed congestion management model is used within a time frame of 1 hour. Thus, frequency and transient instabilities, which are typically much faster phenomena, are not taken into account in this paper.

The proposed procedure can be improved including models for additional control components. However, the aim of this paper is not to develop an OPF-based tool for controlling tap-changing transformers and flexible ac transmission system (FACTS) devices (issues still open for creative research) but rather to provide an efficacious congestion-relieving tool within a 1-hour time framework.

We would like to emphasize that this paper focuses on congestion management, not on voltage stability assessment. Within this framework, to properly address the tradeoff between high accuracy and low complexity, we believe that the static proposed model provides an appropriate compromise. Moreover, the validity of such an approach is based on well-assessed practice, as reported in [15].

#### D. Solution

Problems formulated in Subsections II-B and II-C are relatively small, well-behaved nonlinear programming problems that can be easily solved using appropriate software, e.g., CONOPT, MINOS, or SNOPT [16].

### III. ECONOMIC EFFICIENCY METRICS

For both congestion management procedures, the increment in revenues for producers participating in congestion management is computed as

$$\sum_{j \in \mathcal{G}} \left( r_{G_j}^{\text{up}} \Delta P_{G_j}^{\text{up}} + r_{G_j}^{\text{down}} \Delta P_{G_j}^{\text{down}} \right). \quad (34)$$

That is, (34) represents payments to producers for adjusting power production (up and down).

The revenues for consumers participating in congestion management is computed as

$$\sum_{i \in \mathcal{D}} \left( r_{D_i}^{\text{up}} \Delta P_{D_i}^{\text{up}} + r_{D_i}^{\text{down}} \Delta P_{D_i}^{\text{down}} \right). \quad (35)$$

That is, (35) represents payments to consumers for adjusting power consumptions (up and down).

The total cost associated to congestion management is provided by (34) plus (35).

It should be noted that the techniques proposed in Sections II-B and II-C result in different producer and consumer payments and therefore in a different total congestion management cost.

This total cost is a measure of the decrement in social welfare due to congestion management. This cost might be allocated (e.g., *pro rata*) among all market participants, generators, and

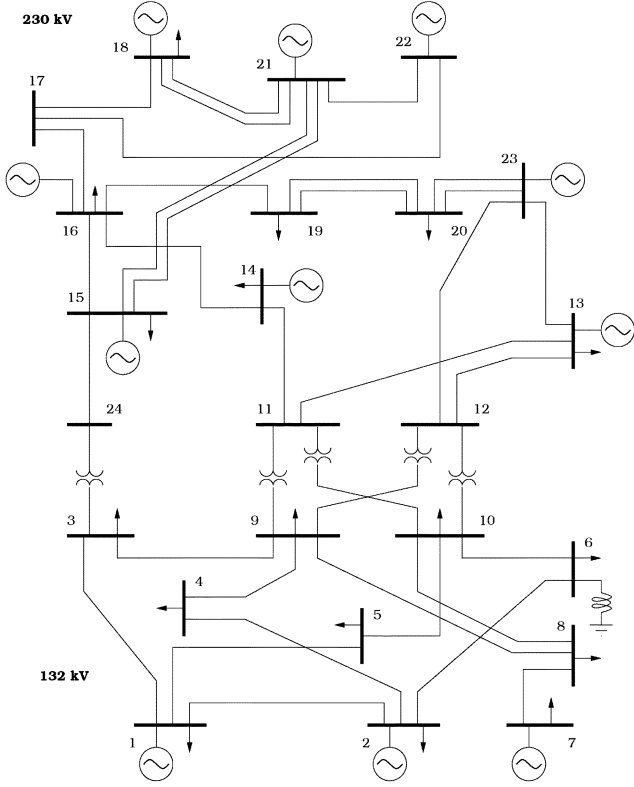

Fig. 1. IEEE 24-bus RTS [17].

demands. Alternatively, it might be allocated to those generators and demands that do not contribute to the actual congestion relieving by changing their productions or consumptions.

#### IV. CASE STUDY

A case study based on the IEEE RTS, depicted in Fig. 1, is presented in this section. Topology, line, and generator data can be found in [17, Fig. 1 and Tables IX and XII]. Offline stability capacity limits and thermal capacity limits of the lines are also given in [17, Table XII]. The offline stability capacity limit of line 14-16 is reduced to 300 MVA in this paper (instead of 500 MVA) so that congestion occurs. Generator and demand data are given in the Appendix.

Note that functions  $h_m(\theta)$  and  $p_n^o(\theta)$  represent active power flow through any line and active power injection in any node, respectively (considering voltages magnitudes equal to one). Then, both congestion management methods include transmission losses.

Price bids by generators and demands to alter their scheduled productions and consumptions (as determined in the day-ahead market) are reported in Tables II and III, respectively (in the Appendix). These values have been selected arbitrarily close to the corresponding marginal cost values and considering adjusting up slightly more expensive than adjusting down for generators and the opposite for demands.

All simulations have been obtained using CONOPT under GAMS [16]. On a Pentium IV 2.66-GHz computer, the classical congestion management method takes about 0.1 s, while the proposed congestion management method converges in three iterations (three solutions of the OPF problem (12)–(32) and (7)–(11) are needed) and takes about 1.5 s of CPU time.

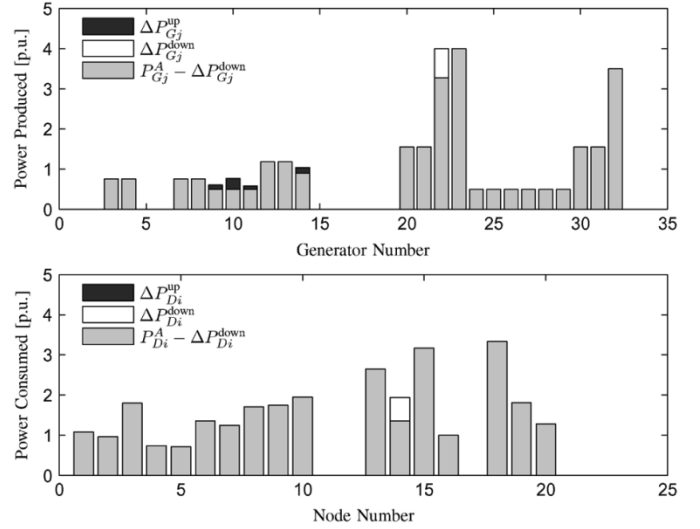

Fig. 2. Productions and consumptions using the classical congestion management method for the 24-bus system.

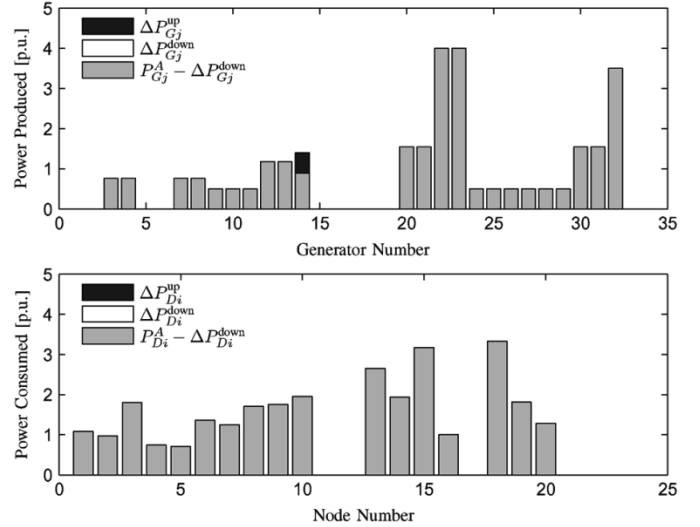

 Fig. 3. Productions and consumptions using the proposed method with  $\lambda_{\min} = 0.1$  for the 24-bus system.

Fig. 2 depicts the solution of the classical congestion-relieving problem (1)–(11) for the IEEE RTS using as initial values the market-clearing results  $P_{G_j}^A, \forall j$ , and  $P_{D_i}^A, \forall i$  (provided in Tables II and III). This solution shows changes in the power outputs of some generators and in the consumption of one demand to relieve a stability overloading in line 14–16 (constraint  $P_{ST,m}^{\max}$  of line 14–16 is binding).

On the other hand, Fig. 3 depicts the solution of the proposed congestion-relieving problem (12)–(32), (7)–(11) for  $\lambda_{\min} = 0.1$  and for the same initial market-clearing results  $P_{G_j}^A, \forall j$  and  $P_{D_i}^A, \forall i$  as the ones used for the classical congestion problem. In this case, only one  $\Delta P_{G_j}^{up}$  is nonzero because transmission losses have to be supplied. This solution ensures a reasonable security margin, as  $\lambda_{\min} = 0.1$  means that the system can stand at least a 10% load increase. However, no load adjustment is required, thus resulting in a cheaper solution than the one achieved solving the classical congestion management problem (1)–(11), as illustrated in Table I.

TABLE I  
PAYMENTS FOR THE DIFFERENT CONGESTION MANAGEMENT PROCEDURES

Method	Contingency (line outage)	$\lambda_{\min}$	Payments to Producers (\$/h)	Payments to Consumers (\$/h)
Classical	—	—	1681	1280
Proposed	—	0.1	1002	0
Proposed	15-24	0.2	613	3870
Proposed	12-23	0.2	596	3826
Proposed	7-8	0.2	1256	6484

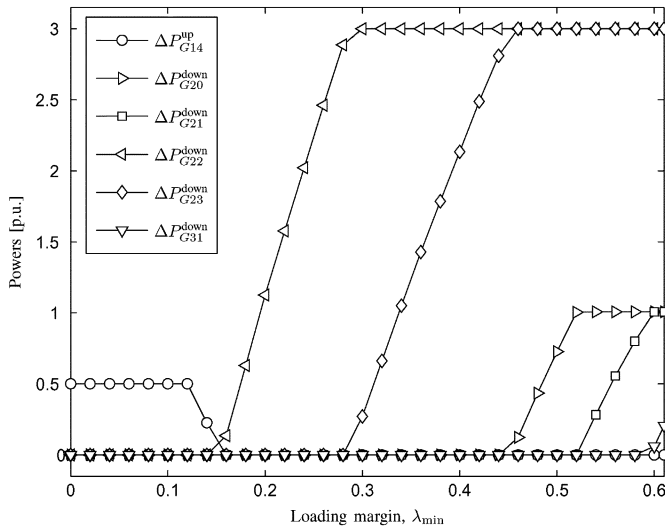

Fig. 4. Power production adjustments as a function of  $\lambda_{\min}$  for the 24-bus system.

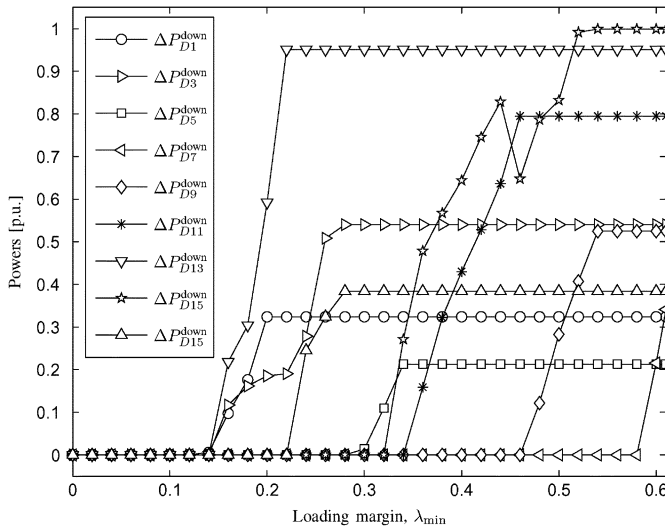

Fig. 5. Relevant power consumption adjustments as a function of  $\lambda_{\min}$  for the 24-bus system.

The proposed method also allows computing a set of optimal solutions as a function of  $\lambda_{\min}$ . Figs. 4 and 5 depict the adjustments that take place in the power productions and consumptions, respectively, for  $\lambda_{\min} \in [0.0, 0.61]$ . The solutions do not change up to  $\lambda_{\min} \approx 0.12$ , which is, in turn, the security margin of the initial solution provided by the market clearing. However, it would not be correct to impose  $\lambda = \lambda_{\min}$  as the initial solution of the market-clearing procedure, namely,  $P_{G_j}^A$  and  $P_{D_i}^A$

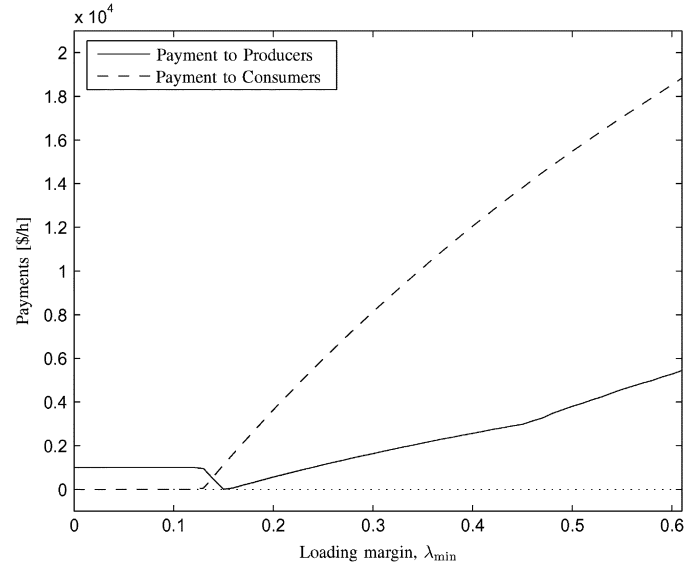

Fig. 6. Payments for production and consumption adjustments as a function of  $\lambda_{\min}$  for the 24-bus system.

could be characterized by a higher level of security. The powers of both productions and consumptions change (production increases and consumption decreases) for  $\lambda_{\min} > 0.12$  in order to provide the required security margin. Furthermore, payments to consumers increase as the security margin increases, since the higher the system security, the higher the power adjustments, as depicted in Fig. 6. Fig. 6 illustrates also payments to producers, which show a similar behavior as the payments to consumers, except for a local decrease for  $0.13 < \lambda_{\min} < 0.15$ . This behavior is due to power losses adjustments (power losses decrease as the power consumption decreases). However, the sum of payments to consumers and to producers cannot decrease as  $\lambda_{\min}$  increases; otherwise, the solutions of (12)–(32) and (7)–(11) would not be optimal.

In this case study, the maximum security margin is  $\lambda = 0.6125$ , i.e., for  $\lambda_{\min} > 0.6125$ , problem (12)–(32) and (7)–(11) becomes infeasible. Observe that determining the critical loading condition of a given market-clearing solution is a by-product of the proposed congestion-relieving technique.

The proposed method also allows embedding an  $N - 1$  contingency analysis, which can be easily included in (14) and (16). Figs. 7–9 illustrate the effect of contingencies on lines 15–24, 12–23, and 7–8, respectively, for a minimum required security margin  $\lambda_{\min} = 0.2$ . Line outages lead to nonzero power consumption increments  $\Delta P_{D_i}^{\text{up}}$ , as expected, since transmission system congestion increases. Taking into account contingencies leads also to a more expensive solution than the one associated with the classical congestion management solution (see Table I).

## V. CONCLUSION

This paper provides a novel technique for congestion management. This technique does not rely on enforcing transmission capacity limits related to stability and computed offline. Instead, it relies on imposing OPF-based constraints that target voltage instabilities. The proposed technique results in both more economical and more secure operating conditions than those re-

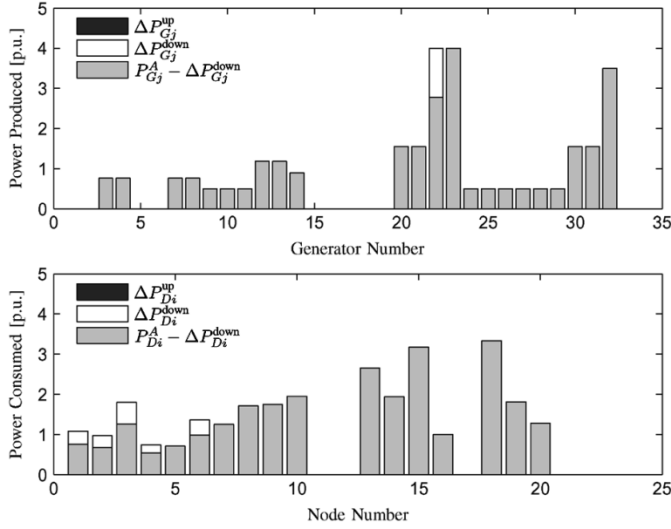

Fig. 7. Productions and consumptions with  $\lambda_{min} = 0.2$  for line 15–24 unavailable in the 24-bus system.

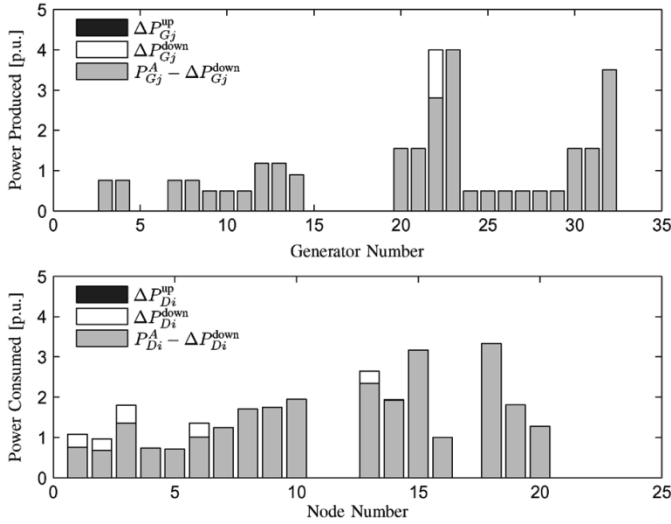

Fig. 8. Productions and consumptions with  $\lambda_{min} = 0.2$  for line 12–23 unavailable in the 24-bus system.

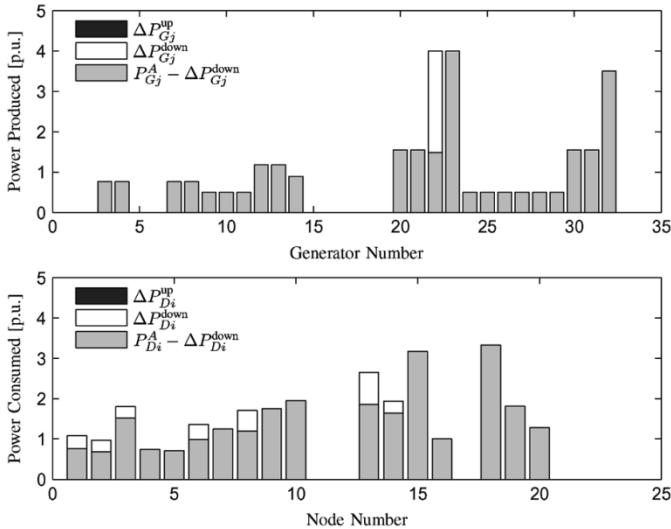

Fig. 9. Productions and consumptions with  $\lambda_{min} = 0.2$  for line 7–8 unavailable in the 24-bus system.

TABLE II  
GENERATOR DATA

Generator	$P_{G_j}^A$ (MW)	$P_{G_j}^{min}$ (MW)	$P_{G_j}^{max}$ (MW)	$r_{G_j}^{up}$ (\$/MWh)	$r_{G_j}^{down}$ (\$/MWh)
1,2	0.0	15.80	20.0	—	—
3,4	76.0	15.20	76.0	16.0	15.0
5,6	0.0	15.80	20.0	—	—
7,8	76.0	15.20	76.0	16.0	15.0
9-11	50.0	25.00	100.0	22.0	21.0
12,13	118.2	68.95	197.0	22.0	21.0
14	89.6	68.95	197.0	20.0	19.0
15-19	0.0	2.40	12.0	—	—
20,21	155.0	54.25	155.0	12.0	11.0
22,23	400.0	100.00	400.0	7.0	5.0
24-29	50.0	50.00	50.0	1000.0	1000.0
30,31	155.0	54.25	155.0	12.0	11.0
32	350.0	140.00	350.0	12.5	11.5

TABLE III  
DEMAND DATA

Node	$P_{D_i}^A$ (MW)	$P_{D_i}^{min}$ (MW)	$P_{D_i}^{max}$ (MW)	$r_{D_i}^{up}$ (\$/MWh)	$r_{D_i}^{down}$ (\$/MWh)
1	108	75.60	142.56	20.0	22.0
2	97	67.84	128.04	20.0	22.0
3	180	126.00	237.60	20.0	22.0
4	74	51.81	97.68	21.0	23.0
5	71	49.71	93.72	21.0	23.0
6	136	95.22	179.52	21.0	23.0
7	125	87.51	165.00	21.0	24.0
8	171	119.70	225.72	22.0	24.0
9	175	122.52	231.00	20.0	23.0
10	195	136.50	257.40	21.0	23.0
13	265	185.52	349.80	20.0	22.0
14	194	135.81	256.08	20.0	22.0
15	317	221.91	461.64	19.0	21.0
16	100	70.02	132.00	19.0	21.0
18	333	233.10	439.56	19.0	21.0
19	181	126.72	238.92	19.0	22.0
20	128	89.61	168.96	19.0	21.0

sulting for imposing offline transmission capacity limits. The appropriate functioning of the technique is demonstrated using the IEEE 24-bus RTS.

APPENDIX

Table II provides generator data. The second column of this table gives the active power produced by each generator as determined by the market-clearing procedure  $P_{G_j}^A$ . Columns 3 and 4 provide the minimum power output and the capacity of each generator, respectively. The last two columns provide the prices  $r_{G_j}^{up}$  and  $r_{G_j}^{down}$  offered by each generator to increase and decrease, respectively, its pool power schedule for congestion management purposes.

Table III provides demand data. The second column of this table provides the active power consumed by each demand as determined by the market-clearing procedure  $P_{D_i}^A$ . The third and fourth columns represent the minimum and maximum power requirements of each demand  $P_{D_i}^{min}$  and  $P_{D_i}^{max}$ , respectively. Finally, the last two columns provide the prices  $r_{D_i}^{up}$  and  $r_{D_i}^{down}$  offered by each demand to increase and decrease, respectively, its pool power schedule for congestion management purposes.

## REFERENCES

- [1] A. L. Motto, F. D. Galiana, A. J. Conejo, and J. M. Arroyo, "Network-constrained multiperiod auction for a pool-based electricity market," *IEEE Trans. Power Syst.*, vol. 17, no. 3, pp. 646–653, Aug. 2002.
- [2] J. M. Arroyo and A. J. Conejo, "Multiperiod auction for a pool-based electricity market," *IEEE Trans. Power Syst.*, vol. 17, no. 4, pp. 1225–1231, Nov. 2002.
- [3] W. D. Rosehart, C. A. Cañizares, and V. H. Quintana, "Multiobjective optimal power flows to evaluate voltage security costs in power networks," *IEEE Trans. Power Syst.*, vol. 18, no. 2, pp. 578–587, May 2003.
- [4] F. Milano, C. A. Cañizares, and M. Invernizzi, "Multiobjective optimization for pricing system security in electricity markets," *IEEE Trans. Power Syst.*, vol. 18, no. 2, pp. 596–604, May 2003.
- [5] T. W. Gedra, "On transmission congestion and pricing," *IEEE Trans. Power Syst.*, vol. 14, no. 1, pp. 241–248, Feb. 1999.
- [6] H. Singh, S. Hao, and A. Papalexopoulos, "Transmission congestion management in competitive electricity markets," *IEEE Trans. Power Syst.*, vol. 13, no. 2, pp. 672–680, May 1998.
- [7] P. Gribik, G. A. Angelidis, and R. R. Kovacs, "Transmission access and pricing with multiple separate energy forward markets," *IEEE Trans. Power Syst.*, vol. 14, no. 3, pp. 865–876, Aug. 1999.
- [8] T. Shu and G. Gross, "A congestion-management allocation mechanism for multiple transaction networks," *IEEE Trans. Power Syst.*, vol. 17, no. 3, pp. 826–833, Aug. 2002.
- [9] E. Bompard, P. Correia, G. Gross, and M. Amelin, "Congestion-management schemes: A comparative analysis under a unified framework," *IEEE Trans. Power Syst.*, vol. 18, no. 1, pp. 346–352, Feb. 2003.
- [10] M. Ilic, F. Galiana, and L. Fink, *Power Systems Restructuring: Engineering and Economics*. Norwell, MA: Kluwer, 1998.
- [11] G. B. Sheblé, *Computational Auction Mechanisms for Restructured Power Industry Operation*. Norwell, MA: Kluwer, 1999.
- [12] M. Shahidehpour and M. Alomoush, *Restructured Electric Power Systems*. New York: Marcel Dekker, 2001.
- [13] M. Shahidehpour, H. Yamin, and Z. Li, *Market Operations in Electric Power Systems: Forecasting, Scheduling and Risk Management*. New York: Wiley, 2002.
- [14] M. Shahidehpour and Y. Wang, *Communication and Control in Electric Power Systems*. New York: Wiley, 2003.
- [15] C. A. Cañizares, Ed., (2002, Aug.) Voltage stability assessment: Concepts, practices and tools. IEEE-PES Power System Stability Subcommittee Special Publication. [Online]. Available: <http://www.power.uwaterloo.ca>.
- [16] A. Brooke, D. Kendrick, A. Meeraus, R. Raman, and R. E. Rosenthal, *GAMS, a User's Guide*. Washington, DC: GAMS Development Corporation, 1998.
- [17] Reliability Test System Task Force, "The IEEE reliability test system 1996," *IEEE Trans. Power Syst.*, vol. 14, no. 3, pp. 1010–1020, Aug. 1999.



**Antonio J. Conejo** (F'04) received the M.S. degree from Massachusetts Institute of Technology, Cambridge, in 1987 and the Ph.D. degree from the Royal Institute of Technology, Stockholm, Sweden, in 1990.

He is currently a Full Professor at the Universidad de Castilla-La Mancha, Ciudad Real, Spain. His research interests include control, operations, planning, and economics of electric energy systems, as well as statistics and optimization theory and its applications.



**Federico Milano** (M'03) received the Electrical Engineering and Ph.D. degrees from the University of Genoa, Genoa, Italy, in 1999 and 2003, respectively.

From September 2001 to December 2002, he was with the Electrical and Computer Engineering Department, University of Waterloo, Waterloo, ON, Canada, as a Visiting Scholar. He is currently an Assistant Professor of electrical engineering at the Universidad de Castilla-La Mancha, Ciudad Real, Spain. His research interests are voltage stability, electricity market, and computer-based power

system analysis and control.



**Raquel García-Bertrand** (M'06) was born in London, U. K., in 1978. She received the Ingeniero Industrial and Ph.D. degrees from the Universidad de Castilla-La Mancha, Ciudad Real, Spain, in 2001 and 2005, respectively.

She is currently a Researcher in electrical engineering at the Universidad de Castilla-La Mancha. Her research interests include control, operations, planning, and economics of electric energy systems.